

playmobil®

Pirates



71420



**Manta-Hunter Myles** und seine Piratencrew sind die besten Seemonsterjäger der Sieben Meere! Piratenkönigin **Rohanna Razor-Tide** bittet um ihre Hilfe, als die Deepers – menschliche Seemonster – und ihr Anführer **Dark Kraken** die Piratenwelt angreifen ...

**Manta-Hunter Myles** and his pirate crew are the best sea monster hunters of the Seven Seas! Pirate Queen **Rohanna Razor-Tide** seeks their help as the Deepers – human-like sea monsters – and their leader **Dark Kraken** attack the pirate world ...



**Manta Hunter Myles** et son équipage de pirates sont les meilleurs chasseurs de monstres des Sept Mers ! La Reine Pirate **Rohanna Razor Tide** leur demande de l'aide face à une nouvelle menace : les Deepers, des monstres marins semblables à des humains. Leur chef **Dark Kraken** va bientôt attaquer le monde des pirates ...



¡**Manta-Hunter Myles** y su tripulación pirata son los mejores cazadores de monstruos marinos de los Siete Mares! La Reina Pirata **Rohanna Razor-Tide** busca su ayuda mientras los Deepers, monstruos marinos, y su líder **Dark Kraken** atacan el mundo pirata ...



## WARNING: CHOKING HAZARD

Small parts. Not for children under 3 years.

"Ne concerne que les USA"

Wichtige Unterlagen, bitte sorgfältig aufbewahren!  
Important: Please keep these instructions for future reference!  
Documents importants, à conserver soigneusement!  
¡Por favor, guarde estas instrucciones para el futuro!  
Belangrijke documenten, bewaar deze zorgvuldig!

Abbildungen können vom Original abweichen.  
Product may differ from image shown.  
Les illustrations peuvent différer de l'original.  
Las ilustraciones pueden diferir del original.  
Afbeeldingen kunnen verschillen van het  
werkelijke artikel.

Serviceadressen finden Sie in allen  
PLAYMOBIL-Prospekten

Addresses of Customer Service Depart-  
ments are shown in all PLAYMOBIL  
catalogues

L'adresse du service consommateurs  
est indiquée dans tous les catalogues  
PLAYMOBIL

Troverete gli indirizzi dei centri di  
assistenza in tutti i cataloghi PLAYMOBIL

**UK-Importer:**  
**Playmobil UK Ltd.**  
**Regency House**  
**1 Miles Gray Road**  
**Basildon**  
**Essex**  
**SS14 3RW**  
**UK**

**UK  
CA**

In alle PLAYMOBIL catalogi vindt u  
het adres van onze klantendienst.

Las Direcciones de los Departamentos  
de Servicio al Consumidor se encuentran  
en todos los catálogos PLAYMOBIL

Η διεύθυνση του Γραφείου Εξυπηρέτησης  
Καταναλωτών PLAYMOBIL βρίσκεται σε  
όλους τους καταλόγους PLAYMOBIL.

pronounced: plāymōbēel

30 29 2890

30 24 7320



30 00 5235



30 02 7895

30 00 5245

1

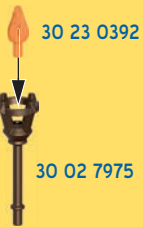

30 06 8413



30 02 7985

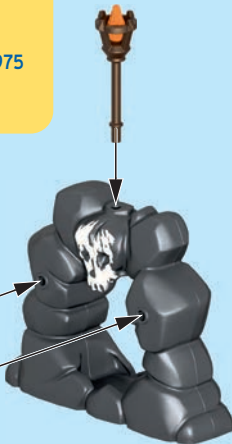

30 64 7808

2

30 02 7965



30 03 9432

30 08 1382



1

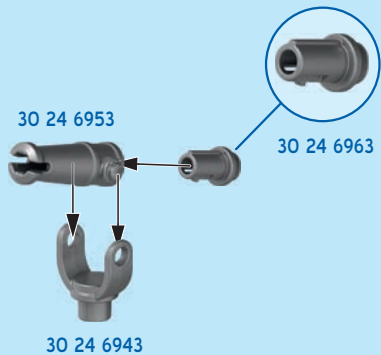

2



3



30 02 7815



**DE AT CH LU BE** **ACHTUNG!** Nur mitgelieferte PLAYMOBIL Geschosse verwenden. Nicht auf Augen oder Gesicht zielen.

**US GB CA MT IE** **WARNING!** Only use the PLAYMOBIL projectiles supplied. Do not aim at eyes or face.

**FR CA BE LU CH** **ATTENTION!** Seulement utiliser les projectiles PLAYMOBIL fournis. Ne pas viser les yeux ou le visage

**ES MX** **¡ADVERTENCIA!** Utiliza únicamente los proyectiles PLAYMOBIL suministrados. No apuntar a los ojos ni a la cara.

**NL BE** **WAARSCHUWING!** Uitsluitend meegeleverde PLAYMOBIL delen gebruiken. Niet op ogen of gezicht richten.

**IT CH** **AVVERTENZA!** Usare soltanto i proiettili PLAYMOBIL in dotazione. Non mirare agli occhi o al viso.

**PT** **ATENÇÃO!** Usar apenas os projecteis PLAYMOBIL juntamente fornecidos. Não apontar para os olhos ou face.

**DK** **ADVARSEL!** Anvend kun de medfølgende PLAYMOBIL projektiler. Sigt ikke mod øjne eller ansigt.

**NO** **ADVARSEL!** Benytt kun PLAYMOBIL prosjektil som leveres med. Sikt ikke på ansikt eller øyne.

**SE FI** **VARNING!** Använd endast medlevererade PLAYMOBIL-skott. Ei saa kohdistaa suoraan silmiin tai kasvoihin.

**FI** **VAROITUS!** Käytä vain mukana toimitettuja PLAYMOBIL-ammuk-  
sia. Älä tähtää päin silmiä tai kasvoja.

**HU** **FIGYELMEZTETÉS.** Csak a csomagban található PLAYMOBIL lövedékeket szabad használni. Tilos szemre vagy arcra célozni.

**CZ** **UPOZORNĚNÍ!** Používejte pouze střely PLAYMOBIL, které jsou součástí dodávky. Nemířte na oči nebo na obličej!

**EE** **HOIATUS!** Kasutage ainult kaasaantud PLAYMOBIL'i laskemoona. Ära sihi silmadesse ega näkku.

**LV** **BRĪDINĀJUMS!** Izmantot tikai PLAYMOBIL piegādes komplektā iekļautos šāviņus. Nevērst pret acīm vai seju.

**LT** **ĮSPĖJIMAS!** Naudokite tik pridedamus PLAYMOBIL šaudmenis. Netaikyti į akis arba veidą.

**SI** **OPOZORILO!** Uporabljajte le priložene PLAYMOBIL-ove kroglice. Ne merite v oči ali obraz.

**SK** **UPOZORNENIE!** Používajte len náboje dodávané spolu so sadou PLAYMOBIL. Nemieriť do očí alebo do tváre.

**PL** **OSTRZEŻENIE!** Stosować tylko załączone PLAYMOBIL - kule / pociski. Nie celować w oczy i twarz.

**TR CY** **DIKKAT!** Sadece birlikte verilen PLAYMOBIL mermileri kullanınız. Göze veya yüze doğru tutmayınız.

**GR CY** **Προειδοποίηση!** Να χρησιμοποιούνται αποκλειστικά τα βλήματα της PLAYMOBIL που περιέχονται στη συσκευασία. Μη γίνετα στόχευση στα μάτια ή στο πρόσωπο.

**RO** **AVERTISMENT!** Se folosesc doar proiectilele incluse PLAYMOBIL. Nu se țintește în ochi sau în față.

**BG** **Внимание!** Използвайте само приложени PLAYMOBIL снаряди. Не насочвайте към очите и лицето.

**HR** **UPOZORENJE!** Upotrijebiti samo od strane PLAYMOBIL-a isporučene projektile. Ne ciljati u oči ili lice.

**RU** **Внимание!** Используйте только поставляемые в комплекте снаряды PLAYMOBIL. Не цельтесь в глаза или в лицо.

**CN** **警告!** 仅能用PLAYMOBIL 弹射物, 请勿瞄准眼睛或脸.



1



2

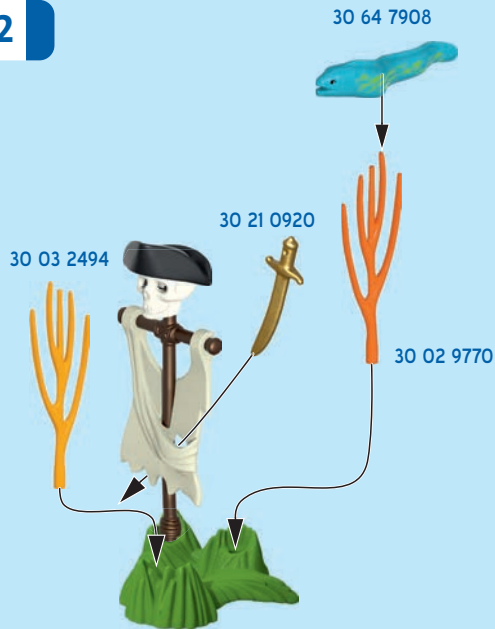

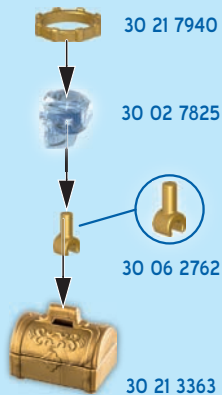

30 64 7928



30 64 7918



30 64 7828



30 24 6243



30 23 9810



30 06 0710



30 70 2045



3x 30 22 8563



**Hisse die Segel**  
und erlebe ein spannendes  
Piratenabenteuer mit Myles und Co.!

**Hoist the sails**  
and embark on an exciting pirate  
adventure with Myles and his crew!

**Hissons les voiles**  
et embarquons pour une palpitante  
aventure avec Myles le pirate et son  
équipage !

**¡Iza las velas**  
y vive una emocionante aventura  
pirata con Myles y su tripulación!





71420



71421



71418



71419



IT  
PAP 22  
Raccolta carta



FR  
DONNEZ  
OU  
RECYCLEZ



ASSOCIATION



MAGASIN



OU



OU



LIVRAISON



DÉCHÈTERIE

Adresses sur [quefairedevesdets.fr](http://quefairedevesdets.fr)



©2023 geobra Brandstätter Stiftung & Co. KG • Brandstätterstr. 2-10  
90513 Zimdorf, Germany • No. 30 82 0706 08.23