

playmobil®

NOVELMORE



71299



Nachdem die Novelmorianer und die Burnham Raiders ihre Feindseligkeiten begraben und gemeinsam die fünf Reiche vor dem Untergang bewahrt haben, müssen sie sich gegen den dunklen Zauberer, Umbrathor, erneut verbünden. Auf der Suche nach alten Verteidigungsplänen stoßen sie in den Archiven Novelmores auf eine weitere Prophezeiung: Die Weissagung erzählt von dem sogenannten Guardian, einem mächtigen Krieger, der das sagenumwobene Wächter-Schwert trägt – jene vor Jahrhunderten von Jahren geschmiedete Waffe, die allein zur Verteidigung eingesetzt wird und dem Reich seines Trägers Schutz und Sicherheit für alle Zeiten garantiert. Um den Guardian ausfindig zu machen, veranstalten Arwynn und Pyralia das Turnier des Wächters. Hier können sich die Ritter Novelmores und Burnhams in den verschiedensten Disziplinen beweisen und behaupten. Als Dario jedoch herausfindet, dass nur ein einziges Reich am Ende vom Guardian beschützt werden kann, wird aus dem anfangs freundschaftlichen Turnier schnell bitterer Ernst. Die Unterstützung aus der Schattendimension vom längst verloren geglaubten Brody kommt den Raiders da genau recht.

After ending their hostilities and saving the Five Realms from collapse, the Novelmorians and the Burnham Raiders must once again unite against the dark wizard, Umbrathor. In the search for old defensive plans they stumble across another prophecy in the Novelmor archives: The prophecy tells of the Guardian, a mighty warrior, who bears the legendary Guardian Sword, a weapon forged centuries ago, that can only be used in defence and guarantees the realm of its bearer protection and safety for all time. To track down the Guardian, Arwynn and Pyralia hold the Tournament of the Guardian. Here the Novelmor and Burnham knights can contend and prove themselves in the different disciplines. However, when Dario finds out that only one realm can ultimately be protected by the Guardian, the initially friendly tournament quickly turns to bitter seriousness. Support from the long-lost Brody from the Shadow Dimension is just what the Raiders need.

Après avoir enterré la hache de guerre et empêché ensemble la chute des cinq royaumes, les chevaliers de Novelmor et les Burnham Raiders doivent à nouveau s'unir pour affronter Umbrathor, le sorcier des forces obscures. À la recherche d'anciens plans de défense dans les archives de Novelmor, ils tombent sur une nouvelle prophétie : il existe le Guardian, un puissant guerrier qui porte la légendaire épée du gardien – une épée forgée il y a des millénaires, uniquement utilisée pour se défendre et qui garantit protection et sécurité éternelles au royaume de son porteur. Pour trouver le Guardian, Arwynn et Pyralia décident d'organiser le Tournoi du Gardien. Les chevaliers de Novelmor et de Burnham peuvent s'y affronter dans les disciplines les plus diverses. Mais lorsque Dario apprend que le gardien ne peut protéger qu'un seul royaume, le tournoi qui avait commencé dans une ambiance amicale prend vite une tournure beaucoup plus sérieuse. C'est alors que depuis la dimension de la pénombre, revient Brody qu'on croyait perdu depuis longtemps : un soutien qui tombe à point nommé pour les Raiders.

Después de que los Novelmorianos y los Bandidos de Burnham hayan enterrado sus hostilidades y salvado juntos a los cinco reinos de la ruina, deben aliarse de nuevo contra el mago oscuro, Umbrathor. Mientras buscan antiguos planes de defensa, encuentran otra profecía en los archivos de Novelmor: Habla de un llamado Guardián, un poderoso guerrero que porta la legendaria Espada del Guardián, esa arma forjada hace siglos, utilizada únicamente para la defensa y que garantiza la protección y seguridad del reino de su portador para siempre. Para localizar al Guardián, Arwynn y Pyralia organizan el Torneo del Guardián. Aquí, los caballeros de Novelmor y Burnham pueden demostrar su valía y enfrentarse en una gran variedad de disciplinas. Pero cuando Dario descubre que al final solo un reino puede ser protegido por el Guardián, el torneo, inicialmente amistoso, se convierte rápidamente en algo muy serio. Es entonces cuando, desde la Dimensión de la Sombra, regresa Brody justo a tiempo para apoyar a los Bandidos.

The image shows three LEGO minifigures in a fantasy setting. On the left is Gwynn, a female knight in a blue hooded cloak with a yellow shield. In the center is Arwynn, a male knight with blonde hair wearing silver armor. On the right is Dario, a male inventor wearing a brown hat and goggles, holding a map and a sword. The background features a stone castle on a cliffside under a bright, hazy sky.

**GWYNN**

Erste Ritterin und Anführerin der Elite-Truppe NovelForce • mutig • gewitzt

First knight and leader of the elite NovelForce troop • brave • smart

Première chevalière et cheffe de l'escadron d'élite NovelForce • courageuse • rusée

Primera mujer caballero y líder de la tropa de élite NovelForce • valiente • astuta

**ARWYNN**

Prinz von Novelmore • abenteuerlustig • kämpft für das Gute

Prince of Novelmore • adventurous soul, fights for his cause

Le prince de Novelmore • âme aventureuse, se bat pour la bonne cause

Príncipe de Novelmore • alma aventurera • lucha por la buena causa

**DARIO**

Genialer Erfinder • etwas schüchtern, aber setzt alles für Novelmore und seine Freunde in Bewegung

Brilliant inventor • a little shy but goes out of his way for Novelmore and his friends

Inventeur brillant • un peu timide mais qui se donne du mal pour Novelmore et ses amis

Brillante inventor • un poco tímido pero se desvive por Novelmore y sus amigos

**HINWEIS**  
Note notice  
Atención

Aufbauen leicht gemacht mit nummerierten Tüten.  
Viel Spaß mit deinem neuen PLAYMOBIL-Spielzeug!

Set-up made easy with numbered bags.  
Have fun with your new PLAYMOBIL toy!

Simplicité de montage avec les sachets numérotés.  
Amuse-toi avec tes nouveaux PLAYMOBIL!

El montaje es más fácil  
con las bolsas numeradas.  
¡Diviértete con tu nuevo  
juguete de PLAYMOBIL!





## WARNING: CHOKING HAZARD

Contains a small ball and small parts.  
Not for children under 3 years.

"Ne concerne que les USA"

Wichtige Unterlagen, bitte sorgfältig aufbewahren!  
Important: Please keep these instructions for future reference!  
Documents importants, à conserver soigneusement!  
¡Por favor, guarde estas instrucciones para el futuro!  
Belangrijke documenten, bewaar deze zorgvuldig!

Abbildungen können vom Original abweichen.  
Product may differ from image shown.  
Les illustrations peuvent différer de l'original.  
Las ilustraciones pueden diferir del original.  
Afbeeldingen kunnen verschillen van het werkelijke artikel.

Serviceadressen finden Sie in allen  
PLAYMOBIL-Prospekten

Addresses of Customer Service Depart-  
ments are shown in all PLAYMOBIL  
catalogues

L'adresse du service consommateurs  
est indiquée dans tous les catalogues  
PLAYMOBIL

Troverete gli indirizzi dei centri di  
assistenza in tutti i cataloghi PLAYMOBIL

In alle PLAYMOBIL catalogi vindt u  
het adres van onze klantendienst.

Las Direcciones de los Departamentos  
de Servicio al Consumidor se encuentran  
en todos los catálogos PLAYMOBIL

Η διεύθυνση του Γραφείου Εξυπηρέτησης  
Καταναλωτών PLAYMOBIL βρίσκεται σε  
όλους τους καταλόγους PLAYMOBIL

pronounced: pläymö-bēil

**UK-Importer:**  
**Playmobil UK Ltd.**  
**Regency House**  
**1 Miles Gray Road**  
**Basildon**  
**Essex**  
**SS14 3RW**  
**UK**

**UK  
CA**



30 00 4735

30 24 1903



30 04 8093



30 04 8103



2x 30 09 5663



30 64 2098



FR

**DONNEZ  
OU  
RECYCLEZ**



ASSOCIATION

OU



MAGASIN

OU



LIVRAISON

OU



DÉCHÈTERIE

Adresses sur [quefairedemesdechets.fr](http://quefairedemesdechets.fr)

1



+



© 2022 geobra Brandstätter Stiftung & Co. KG  
Brandstätterstraße 2-10 No. 30818045  
90513 Zirndorf/Germany 05.23

+



30 02 0245



30 02 0305



30 02 0275

30 65 9775

30 20 6502



2

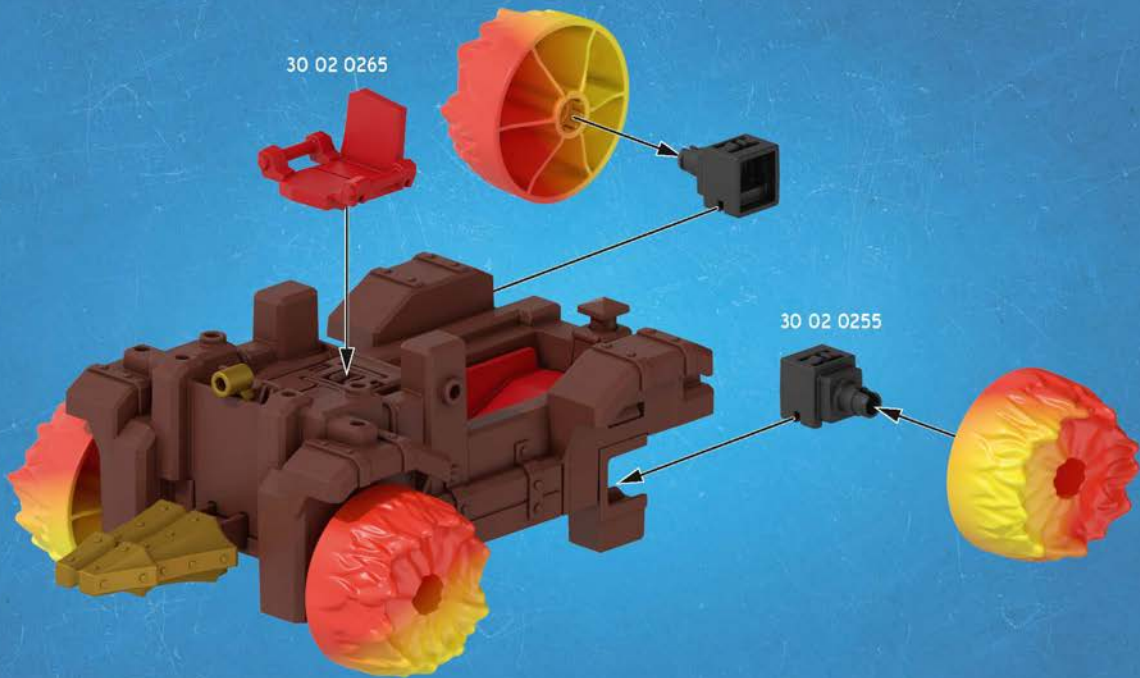



1



30 81 8045



2



3



4



+



30 02 8372

30 25 6163



30 65 2934



30 09 4724



30 22 5912

5



2x 30 02 0315



30 04 0263

6



7

CLICK



30 29 3940

**DE AT CH LU BE** ACHTUNG! Nur mitgelieferte PLAYMOBIL Geschosse verwenden. Nicht auf Augen oder Gesicht zielen.

**US GB CA MT IE** WARNING! Only use the PLAYMOBIL projectiles supplied. Do not aim at eyes or face.

**FR CA BE LU CH** ATTENTION! Seulement utiliser les projectiles PLAYMOBIL fournis. Ne pas viser les yeux ou le visage

**ES MX** ¡ADVERTENCIA! Utiliza únicamente los proyectiles PLAYMOBIL suministrados. No apuntar a los ojos ni a la cara.

**NL BE** WAARSCHUWING! Uitsluitend meegeleverde PLAYMOBIL delen gebruiken. Niet op ogen of gezicht richten.

**IT CH** AVVERTENZA! Usare soltanto i proiettili PLAYMOBIL in dotazione. Non mirare agli occhi o al viso.

**PT** ATENÇÃO! Usar apenas os projécteis PLAYMOBIL juntamente fornecidos. Não apontar para os olhos ou face.

**DK** ADVARSEL! Anvend kun de medfølgende PLAYMOBIL projektiler. Sigt ikke mod øjne eller ansigt.

**NO** ADVARSEL! Benytt kun PLAYMOBIL prosjektil som leveres med. Sikt ikke på ansikt eller øyne.

**SE FI** VARNING! Använd endast medlevererade PLAYMOBIL-skott. Ei saa kohdistaa suoraan silmiin tai kasvoihin.

**FI** VAROITUS! Käytä vain mukana toimitettuja PLAYMOBIL-ammuksia. Älä tähtää päin silmiä tai kasvoja.

**HU** FIGYELMEZTETÉS. Csak a csomagban található PLAYMOBIL lövedékeket szabad használni. Tilos szemre vagy arcra célozni.

**CZ** UPOZORNĚNÍ! Používejte pouze stříky PLAYMOBIL, které jsou součástí dodávky. Nemířte na oči nebo na obličej!

**EE** HOIATUS! Kasutage ainult kaasaantud PLAYMOBIL'i laskemoona. Ära sihi silmadesse ega näkku.

**LV** BRĪDINĀJUMS! Izmantot tikai PLAYMOBIL piegādes komplektā iekļautos šāviņus. Nevērst pret acīm vai seju.

**LT** ĮSPĖJIMASI! Naudokite tik pridėdamus PLAYMOBIL šaudmenis. Netaikyti į akis arba veidą.

**SI** OPOZORILO! Uporabljajte le priložene PLAYMOBIL-ove krogle. Ne merite v oči ali obraz.

**SK** UPOZORNENIE! Používajte len náboje dodávané spolu so sadou PLAYMOBIL. Nemieriť do očí alebo do tváre.

**PL** OSTRZEŻENIE! Stosować tylko załączone PLAYMOBIL - kule / pociski. Nie celować w oczy i twarz.

**TR CY** DİKKATI! Sadece biriktke verilene PLAYMOBIL mermileri kullanınız. Göze veya yüze doğru tutmayınız.

**GR CY** Προειδοποίηση! Να χρησιμοποιούντα αποκλειστικά τα βλήματα της PLAYMOBIL που περιέχονται στη συσκευασία. Μη μνη γίνεται στόχευση στα μάτια ή στο πρόσωπο.

**RO** AVERTISMENTI! Se folosesc doar proiectilele incluse PLAYMOBIL. Nu se țintește în ochi sau în față.

**BG** Внимание! Използвайте само приложени PLAYMOBIL снаряди. Не насочвайте към очите и лицето.

**HR** UPOZORENJE! Upotrijebiti samo od strane PLAYMOBIL-a isporučene projektile. Ne ciljati u oči ili lice.

**RU** Внимание! Используйте только поставляемые в комплекте снаряды PLAYMOBIL. Не цельтесь в глаза или в лицо.

**CN** 警告! 仅能用PLAYMOBIL 弹射物, 请勿瞄准眼睛或脸。





30 07 7830



1

2

3

**CLICK**









71298



71211



71300



71297



70221



70220

# NOVELMORE



71299



71212



71213



71214

# playmobil®

Actiongeladene Novelmore-Abenteurer **jetzt auch als Serie!** Folge uns auf unseren Social-Media-Kanälen.

Action-packed Novelmore adventures, **now a series!** Follow us on social media for exciting updates.

Continue les aventures des Novelmore avec notre **nouveau dessin animé!** Disponible sur nos réseaux sociaux!

Aventuras de Novelmore llenas de acción ¡ahora también como **una serie!** Síguenos en nuestros canales de redes sociales.

[www.playmobil.com](http://www.playmobil.com)



©2023 geobra Brandstätter Stiftung & Co. KG  
Brandstätterstr. 2-10 • 90513 Zirndorf, Germany  
No. 30 81 8805 05.23



Scanne den QR-Code und tauche ein in die Welt von Novelmore.  
Scan the QR code and immerse yourself in the Novelmore world.  
Scanne le code QR et plonge dans l'univers de Novelmore.  
Escanea el código QR y sumérgete en el mundo de Novelmore.

