

playmobil®

CITY  
ACTION



71194

PROMO-PACK

**NEU new**  
Nouveau  
nuevo



Aufbauen leicht gemacht mit nummerierten Tüten.  
Viel Spaß mit deinem neuen PLAYMOBIL-Spielzeug!

Set-up made easy with numbered bags.  
Have fun with your new PLAYMOBIL toy!

Simplicité de montage avec les sachets numérotés.  
Amuse-toi avec tes nouveaux PLAYMOBIL!

El montaje es más fácil con  
las bolsas numeradas.  
¡Diviértete con tu nuevo  
juguete de PLAYMOBIL!





## WARNING: CHOKING HAZARD

Small parts. Not for children under 3 years.

“Ne concerne que les USA“

Wichtige Unterlagen, bitte sorgfältig aufbewahren!  
Important: Please keep these instructions for future reference!  
Documents importants, à conserver soigneusement!  
¡Por favor, guarde estas instrucciones para el futuro!  
Belangrijke documenten, bewaar deze zorgvuldig!

Abbildungen können vom Original abweichen.  
Product may differ from image shown.  
Les illustrations peuvent différer de l'original.  
Las ilustraciones pueden diferir del original.  
Afbeeldingen kunnen verschillen van het werkelijke artikel.

Serviceadressen finden Sie in allen  
PLAYMOBIL-Prospekten

Addresses of Customer Service Depart-  
ments are shown in all PLAYMOBIL  
catalogues

L'adresse du service consommateurs  
est indiquée dans tous les catalogues  
PLAYMOBIL

Troverete gli indirizzi dei centri di  
assistenza in tutti i cataloghi PLAYMOBIL

**UK-Importer:**  
**Playmobil UK Ltd.**  
**Regency House**  
**1 Miles Gray Road**  
**Basildon**  
**Essex**  
**SS14 3RW**  
**UK**

**UK  
CA**

In alle PLAYMOBIL catalogi vindt u  
het adres van onze klantendienst.

Las Direcciones de los Departamentos  
de Servicio al Consumidor se encuentran  
en todos los catálogos PLAYMOBIL

Η διεύθυνση του Γραφείου Εξυπηρέτησης  
Καταναλωτών PLAYMOBIL βρίσκεται σε  
όλους τους καταλόγους PLAYMOBIL.

pronounced: plāymōbēel



30 88 3710

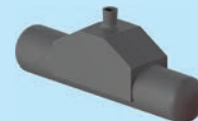

30 80 7952



30 82 6583



30 81 0955





30 64 3965

30 08 4462



30 46 3370



30 46 3360



30 02 2894

30 14 6782

+







4x



30 06 0403

30 82 5730



1

30 23 3493



30 21 6202



2



3



+



30 23 0130

30 07 6854

30 27 0330

30 20 9743

30 23 2820

30 21 0030



1

30 23 2850



30 07 5230

2

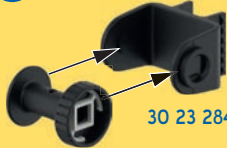

30 23 2840

3



30 82 6583

30 23 2860



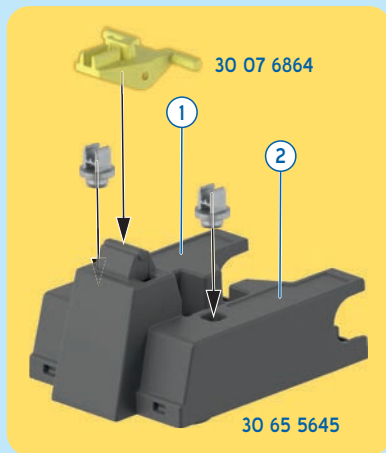

30 21 0700

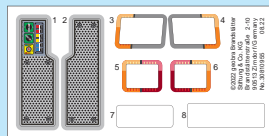

1



2

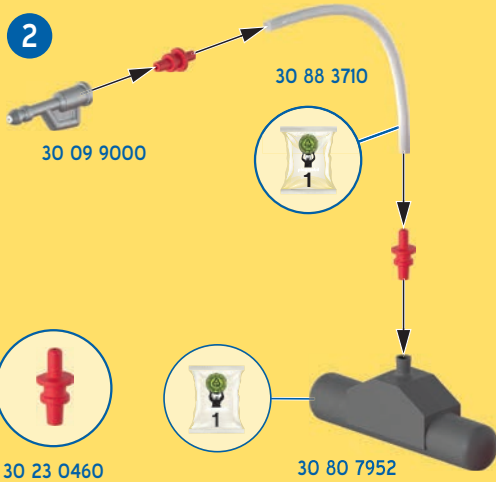





30 08 4752



30 09 2100

**DE AT CH LU BE ACHTUNG!** Nicht auf Augen oder Gesicht zielen. Nur Trinkwasser verwenden. Nach dem Spielen austrocknen lassen.

**US GB CA MT IE WARNING!** Do not aim at eyes or face. Use only tap water. Dry thoroughly after play.

**FR CA BE LU CH ATTENTION!** Ne pas viser les yeux ou le visage. N'utiliser que de l'eau potable. Faire sécher après chaque utilisation.

**ES MX ¡ADVERTENCIA!** No apuntar a los ojos ni a la cara. Utilizar solamente agua potable. Dejar secar antes de guardar.

**NL BE WAARSCHUWING!** Niet op ogen of gezicht richten. Enkel drinkbaar water gebruiken. Na het spelen laten drogen.

**IT CH AVVERTENZA!** Non mirare agli occhi o al viso. Usare solo acqua potabile. Asciugare bene dopo ogni uso.

**PT ATENÇÃO!** Não apontar para os olhos ou face. Utilizar somente água potável. Deixar secar antes de guardar.

**DK ADVARSEL!** Sigst ikke mod øjne eller ansigt. Anvend kun drikkevand. Lad det tørre ud når du er færdig med at lege.

**NO ADVARSEL!** Sikt ikke på ansikt eller øyne. Kun drikkevann skal benyttes. Tørk opp etter at leken er ferdig.

**SE FI WARNING!** Sikta inte mot ögon eller ansikte. Använd endast dricksvatten. Låt torka efter användandet.

**FI VAROITUS!** Ei saa kohdistaa suoraan silmiin tai kasvoihin. Käytä ainoastaan juomavettä. Anna kuivua leikin jälkeä.

**HU FIGYELMEZTETÉS.** Tilos szemre vagy arcra célozni. Kérjük kizárólag ivóvizet használni! Játék után ajánlott a termék kiszáritása!

**CZ UPOZORNĚNÍ!** Nemiřte na oči nebo na obličej! Používejte jen pitnou vodu. Po hraní nechat vyschnout.

**EE HOIATUS!** Ära sihi silmadesse ega näkku. Kasutada üksnes joogivett! Mängimise järel kuivatada!

**LV BRĪDINĀJUMS!** Nevērst pret acīm vai seju. Izmantoj tikai dzeramo ūdeni. Pēc spēlēšanās ļaut nožūt.

**LT ĮSPĖJIMAS!** Netaikyti į akis arba veidą. Naudokite tik geriamąjį vandenį. Pažaidus, išdžiovinkite.

**SI OPOZORILO!** Ne merite v očí ali obraz. V igračo živajte le pitno vodo. Po igri naj se igrača posušiti.

**SK UPOZORNENIE!** Nemieriť do očí alebo do tváre. Používať iba pitnú vodu. Po hre nechajte vyschnúť.

**PL OSTRZEŻENIE!** Nie celować w oczy i twarz. Używaj tylko wodę pitną. Po zabawie pozostaw do wyschnięcia.

**TR CY DİKKAT!** Göze veya yüze doğru tutmayınız. Sadece içme suyu kullanınız. Oyundan sonra kurumaya bırakın.

**GR CY Προειδοποίηση!** Μη μην γίνεται στόχευση στα μάτια ή στο πρόσωπο. Χρησιμοποιείτε μόνο νερό βρύσης. Μόλις τελώσετε, αφήστε το παιχνίδι να στεγνώσει εντελώς.

**RO AVERTISMENT!** Nu se țintește în ochi sau în față. Se folosește doar apă potabilă. După joacă se lasă să se usuce.

**BG Внимание!** Не насочвайте към очите и лицето. Използвайте само питейна вода. След игра оставете да изсъхне.

**HR UPOZORENJE!** Ne ciljati u oči ili lice. Koristiti samo pitku vodu. Poslije igranja pustiti da se osuši.

**RU Внимание!** Не цельтесь в глаза или лицо. Используйте только питьевую воду. Дайте высохнуть после игры.

**CN 警告!** 请勿瞄准眼睛或脸. 仅使用饮用水. 玩耍后要干燥.



71195



71193



71194



DONNEZ OU RECYCLEZ
   
 ASSOCIATION
   
 MARGESIN
   
 OU
   
 FILM
   
 OU
   
 LIVRAISON
   
 OU
   
 DÉCHÈTÈRIE



22%
   
 PAP
   
 100%

PAP 22
   
 Raccolita carta



Adresse sur [qualitefretemesociets.fr](http://qualitefretemesociets.fr)

©2022 geobra Brandstätter Stiftung & Co. KG
   
 Brandstätterstr. 2-10
   
 90513 Zimndorf, Germany
   
 No. 30.82.2436 06.23