

playmobil®

CITY  
ACTION



71149

Broooooaaan!

**HINWEIS**  
Note **notice**  
**Atención**



Aufbauen leicht gemacht mit nummerierten Tüten.  
Viel Spaß mit deinem neuen PLAYMOBIL-Spielzeug!

Set-up made easy with numbered bags.  
Have fun with your new PLAYMOBIL toy!

Simplicité de montage avec les sachets numérotés.  
Amuse-toi avec tes nouveaux PLAYMOBIL!

El montaje es más fácil con  
las bolsas numeradas.  
¡Diviértete con tu nuevo  
juguete de PLAYMOBIL!





# WARNING: CHOKING HAZARD

Small parts. Not for children under 3 years.

"Ne concerne que les USA"

Abbildungen können vom Original abweichen.  
Product may differ from image shown.  
Les illustrations peuvent différer de l'original.  
Las ilustraciones pueden diferir del original.  
Afbeeldingen kunnen verschillen van het werkelijke artikel.

Wichtige Unterlagen, bitte sorgfältig aufbewahren!  
Important: Please keep these instructions for future reference!  
Documents importants, à conserver soigneusement!  
¡Por favor, guarde estas instrucciones para el futuro!  
Belangrijke documenten, bewaar deze zorgvuldig!

**UK-Importer:**  
**Playmobil UK Ltd.**  
**Regency House**  
**1 Miles Gray Road**  
**Basildon • Essex • SS14 3RW • UK**

**UK  
CA**

Serviceadressen finden Sie in allen  
PLAYMOBIL-Prospekten

Addresses of Customer Service Departments are shown in  
all PLAYMOBIL catalogues

L'adresse du service consommateurs est indiquée dans  
tous les catalogues PLAYMOBIL

Troverete gli indirizzi dei centri di assistenza in tutti i  
cataloghi PLAYMOBIL

In alle PLAYMOBIL catalogi vindt u het adres van onze  
klantendienst.

Las Direcciones de los Departamentos de Servicio al  
Consumidor se encuentran en todos los catálogos  
PLAYMOBIL

Η διεύθυνση του Γραφείου Εξυπηρέτησης Καταναλωτών  
PLAYMOBIL βρίσκεται σε όλους τους καταλόγους PLAYMOBIL.

pronounced: play-mō-beel

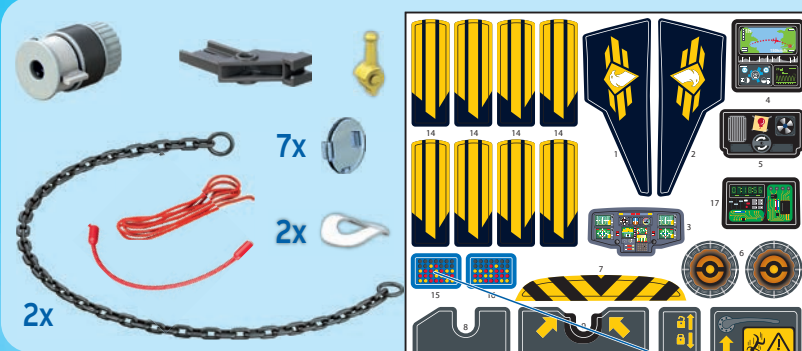



1

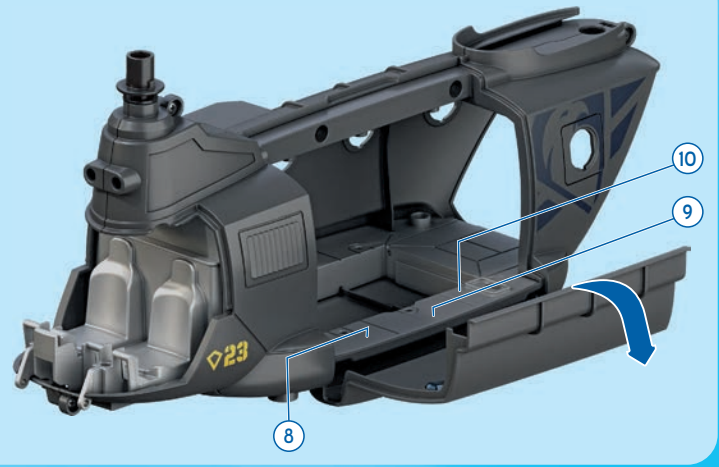

2



3



4

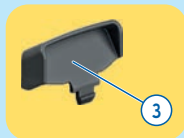

5

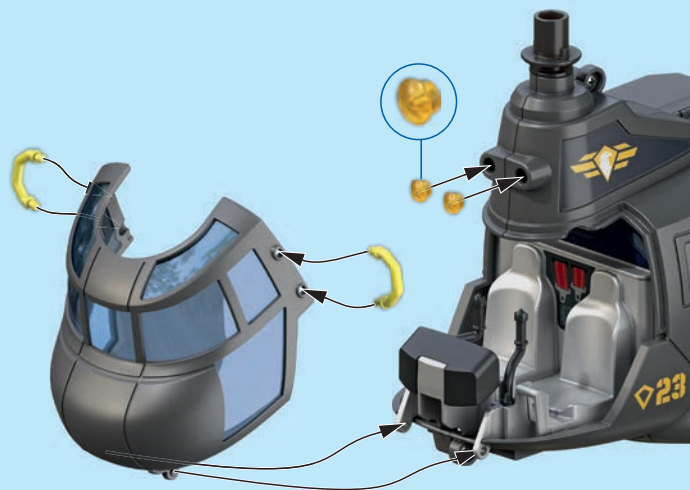

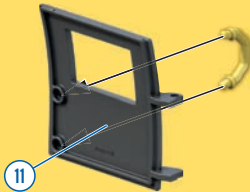
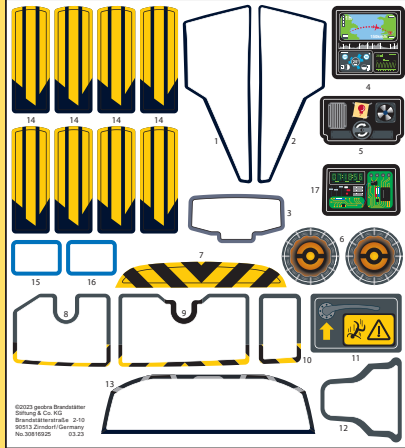

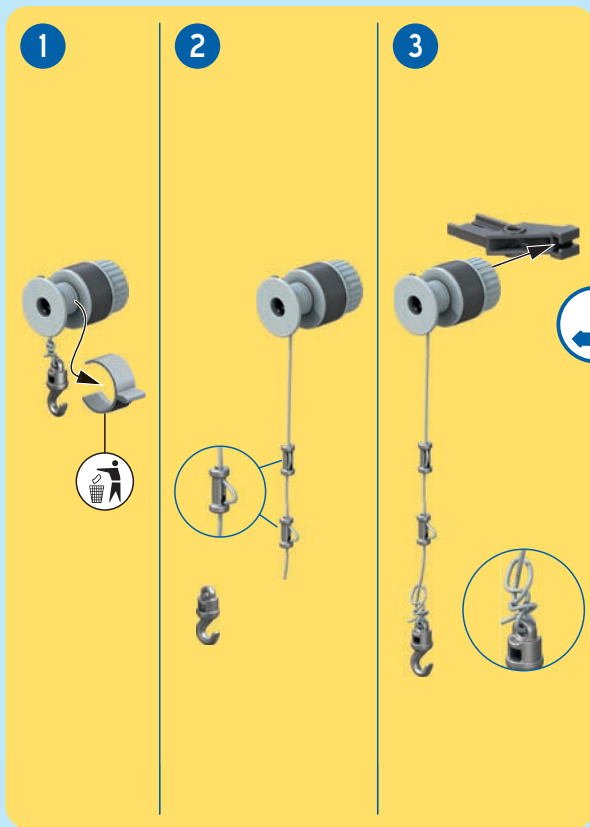

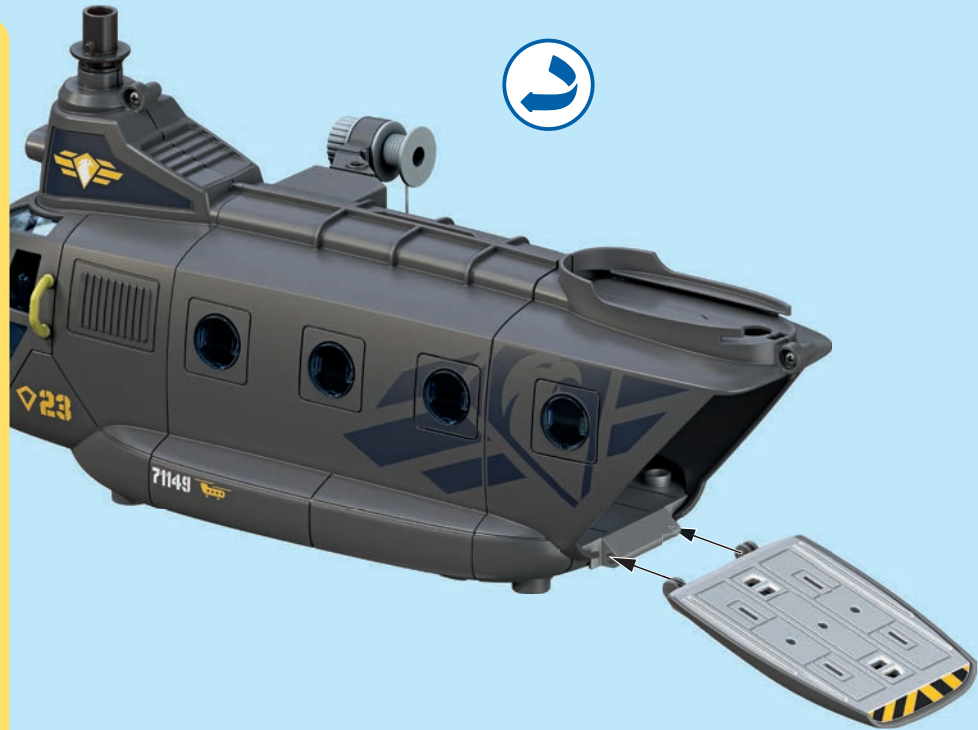
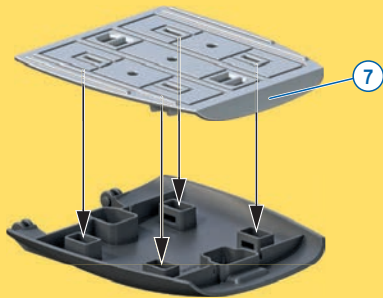
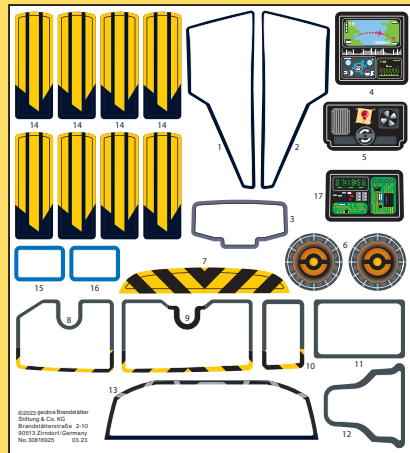



9

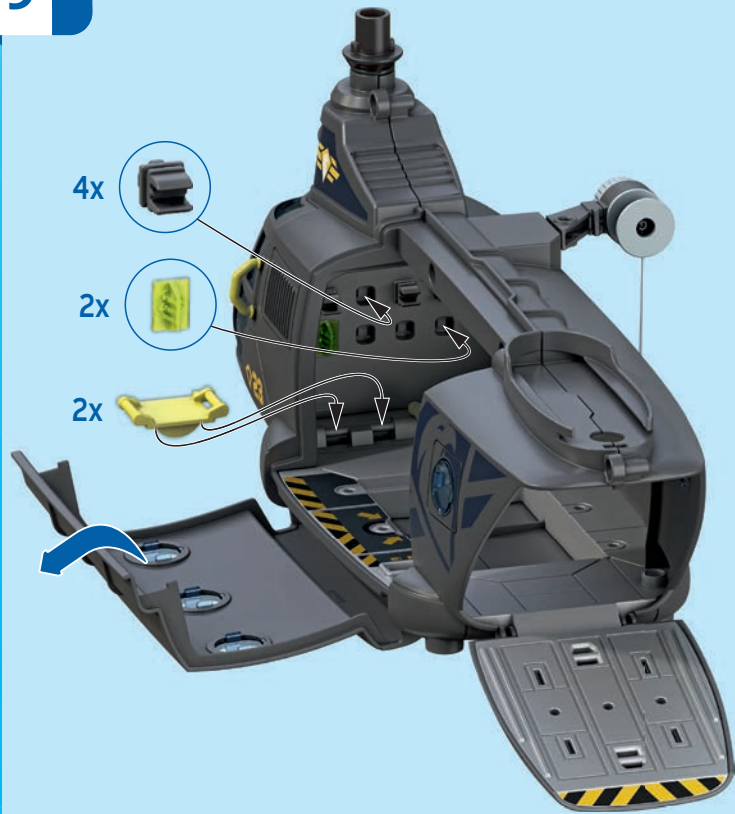

10



11

2x

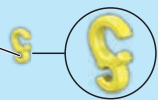

71149 + 71147



+

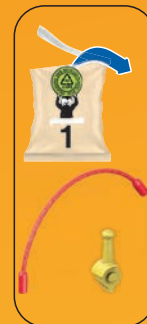

1

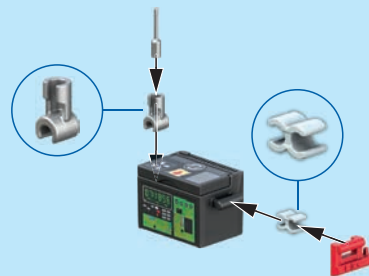
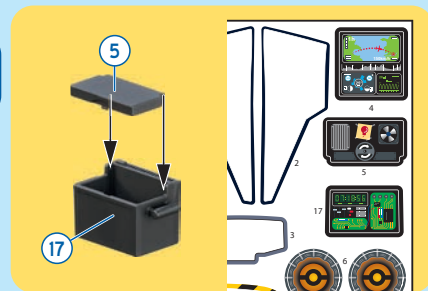

2



3



6x

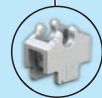

4

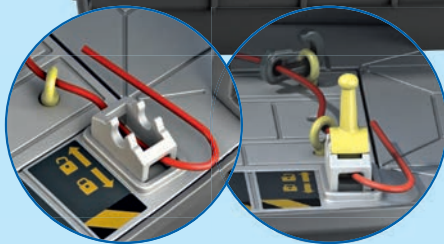
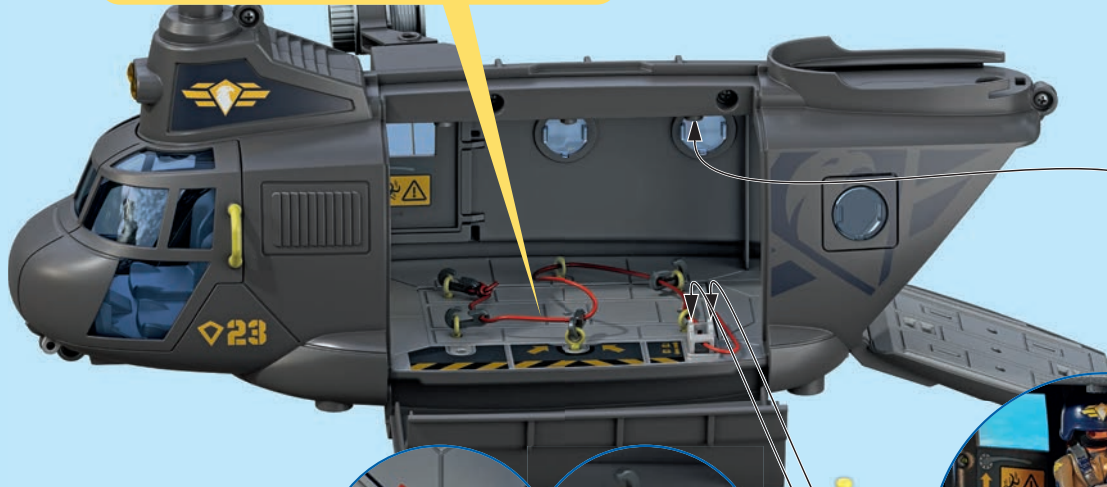
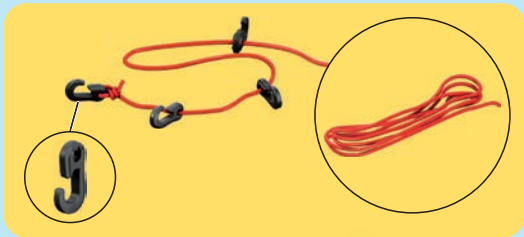

1

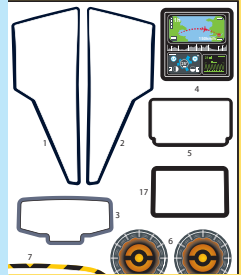

4



2



1



+



4x

1 8x



2 4x



1

2x



2



4x



2

1

+ 2x MICRO 1.5V R03 - LR03 - AAA -

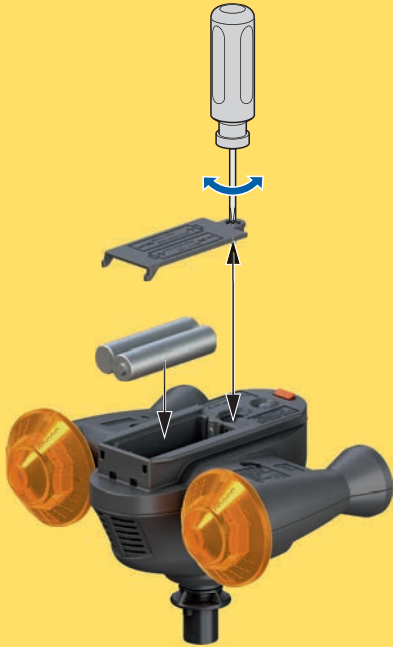

2

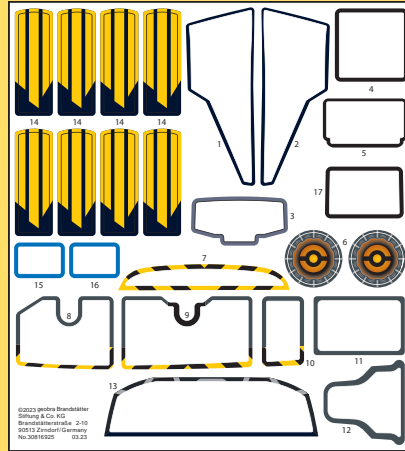

©2013 gornix Brandartikel  
 Stiftung & Co. KG  
 Brandartikelvertrieb, 2-10  
 80532 Zinsdorf Germany  
 No. 808 61003 03-23



CLICK



3

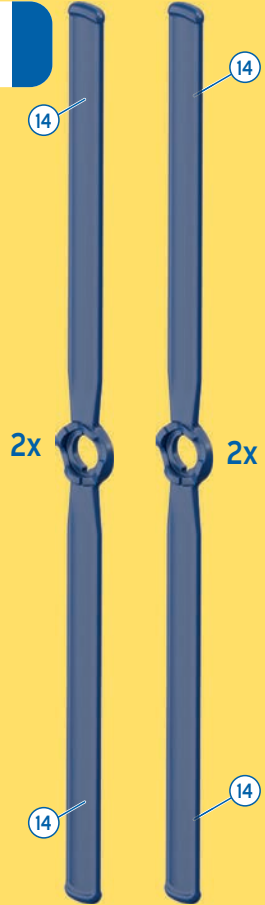

DE AT CH LU BE

Nur angegebene Batterien verwenden. Nicht wiederaufladbare Batterien dürfen nicht geladen werden. Aufladbare Batterien dürfen nur unter Aufsicht von Erwachsenen geladen werden. Aufladbare Batterien sind aus dem Spielzeug herauszunehmen, bevor sie geladen werden. Ungleiche Batterietypen oder neue und gebrauchte Batterien dürfen nicht zusammen verwendet werden. Batterien müssen mit der richtigen Polarität eingelegt werden. Leere Batterien müssen aus dem Spielzeug herausgenommen werden. Die Anschlussklemmen dürfen nicht kurzgeschlossen werden. Batterien regelmäßig auf Auslaufen überprüfen. Verbrauchte Batterien nicht in den Hausmüll werfen, sondern nur bei den bestehenden Sammelstellen oder einem Sondermüllplatz abgeben.

US GB CA MT IE

Only use the stipulated batteries. Non-rechargeable batteries are not to be charged. Rechargeable batteries are only to be charged under adult supervision. Rechargeable batteries are to be removed from the toy before they are recharged. Neither different battery types nor new and used batteries are to be used together. Batteries must be inserted with the correct polarity. Flat batteries are to be removed from the toy. The connecting terminals are not to be short-circuited. Inspect batteries regularly for signs of leakage. Do not dispose of used batteries in the household waste but hand them in at the existing collection points or at a special waste site.

FR CA BE

Seulement utiliser le modèle de piles indiqué. Ne pas recharger de piles non rechargeables. Seulement recharger des piles rechargeables en présence d'adultes. Ôter les piles rechargeables du jouet avant de les recharger. Ne pas utiliser de piles de différents types en même temps ni de piles neuves avec des piles anciennes. Attention à introduire correctement les piles en tenant compte de leur polarité. Ôter les piles usées du jouet. Ne pas court-circuiter les bornes. Vérifier régulièrement si les piles coulent. Ne pas jeter de piles usées avec les ordures ménagères, les déposer dans les centres de récupération.



Points de collecte sur [www.quefairedemesdechets.fr](http://www.quefairedemesdechets.fr) Privilégiez la réparation ou le don de votre appareil!

ES MX

Utiliza únicamente las pilas descritas. No recargues únicamente bajo supervisión de un adulto. Saca las pilas recargables del juguete antes de recargarlas. No utilices juntas pilas de tipos diferentes ni tampoco pilas nuevas con pilas usadas. Inserta las pilas con la polaridad correcta. Saca del juguete las pilas gastadas. No pongas en cortocircuito los bornes de conexión. Comprueba periódicamente si se ha producido una fuga en las pilas. No eches las pilas gastadas a la basura doméstica, deséchalas únicamente en los puestos de recogida previstos o en un depósito de basura especial.

NL BE

Uitsluitend de aangegeven batterijen gebruiken. Niet-herlaadbare batterijen mogen niet geladen worden. Herlaadbare batterijen mogen alleen onder toezicht van volwassenes geladen worden. Oplaadbare batterijen moeten uit het speelgoed genomen worden vooraleer ze te laden. Ongelijke batterijtypes of nieuwe of gebruikte batterijen mogen niet samen gebruikt worden. Batterijen moeten met de correcte polen ingelegd worden. Lege batterijen moeten uit het speelgoed genomen worden. De aansluitingsklemmen mogen niet kortgesloten worden. Regelmatig controleren of de batterijen niet uitgelopen zijn. Lege batterijen niet met het huisvuil verwijderen, maar alleen bij bestaande verzamelcentra of een plaats voor bijzondere afval afgeven.



IT CH

Usare solo le batterie indicate. E' vietato utilizzare le batterie ricaricabili. Le batterie ricaricabili devono essere caricate soltanto in presenza di adulti. Le batterie ricaricabili si estrarrebbero dal giocattolo, prima di essere caricate. I tipi di batteria non uguali o nuovi e le batterie esauste non devono essere usate insieme. Le batterie vanno inserite rispettando la corretta polarità. Le batterie esaurite devono essere rimosse dal giocattolo. I morsetti di collegamento non devono essere messi in corto circuito. Verificare ad intervalli regolari che le batterie non si siano esaurite. Le batterie esauste non vanno smaltite insieme ai rifiuti domestici, bensì portate nei punti di raccolta o nei centri di raccolta per rifiuti speciali.

PT

Usar apenas as pilhas indicadas. Pilhas não recarregáveis não podem ser carregadas. Pilhas recarregáveis só podem ser carregadas sob supervisão de adultos. Pilhas recarregáveis devem ser retiradas do brinquedo, antes de serem carregadas. Não se pode usar em conjunto diferentes tipos de pilha ou pilhas novas e usadas. Pilhas têm de ser inseridas com a polaridade correcta. Pilhas vazias têm de ser retiradas do brinquedo. Não se podem curto-circuitar os terminais. As pilhas têm de ser controladas regularmente quanto a vazamento. Não deixar pilhas gastas no lixo doméstico, mas depositá-las nos pontos de recolha existentes ou entregá-las no estabelecimento que as comercializa.

DK

Anvend kun de angivne batterier. Ikke genopladelige batterier må ikke oplades. Genopladelige batterier må kun oplades under opsyn af voksne. Genopladelige batterier skal tages ud af legetøjet, inden de oplades. Forskellige batterityper eller nye og brugte batterier må ikke anvendes sammen. Batterier skal isættes med den rigtige polaritet. Tomme batterier skal tages ud af legetøjet. Tilslutningsklemmerne må ikke kortsluttes. Kontrollér regelmæssigt batterierne for lækage. Opbrugte batterier må ikke bortskaffes som almindeligt husholdningsaffald, men skal afleveres på et officielt sted for indsamling af brugte batterier eller på den kommunale genbrugsstation.

NO

Benytt kun angitte batterier. Batterier som ikke kan gjenoplades må ikke lades opp. Opladbare batterier må bare lades opp under tilsyn av voksne. Opladbare batterier må tas ut av leketøyet før de lades opp. Ulike batterityper eller nye og brukte batterier må ikke benyttes sammen. Batterier må legges inn med riktig polaritet. Tomme

batterier må tas ut av kjøretøyet. Koplingsklemmene må ikke kortsluttes. Kontrollér batteriene regelmessig for om de lekker ut. Ikke kast oppbrukte batterier i husholdningsavfallet, men lever dem til lokale miljøstasjoner eller til en plass for spesialavfall.

SE FI

Ävänd endast angivna batterier. Batterier som inte är uppladdbara får inte laddas. Uppladdbara batterier får endast laddas om en vuxen person hjälper dig. Ta ur de uppladdbara batterierna ur fordonet innan de laddas. Ävänd inte olika batterityper samtidigt, ävänd heller inte ett nytt och ett gammalt batterie samtidigt. Se till att batterierna ligger åt rätt håll, det finns symboler på batterierna och i batterifacket. Ta ur tomma batterier ur leksaken. Lägg inte ihop anslutningsklämmorna, de kan bli kortslutning. Kontrollera regelbundet att batterierna inte läcker batterisyra. Gamla batterier hör inte hemma i vanliga hushållssopp. Kasta batterier i speciella batteriuppsamlare eller lämna dem till soptippen som specialavfall.

FI

Käytä vain ilmoitettuja paristoja. Ei saa ladata paristoja, jotka eivät ole ladattavia. Ladattavat paristot saa ladata vain aikuisen valvonnassa. Ladattavat paristot on poistettava leikkialusta ennen lataamista. Erilaisia paristotyyppejä tai uusia ja käytettyjä paristoja ei saa käyttää yhdessä. Paristot on asetettava paikoilleen navat oikein päin. Tyhjtät paristot on poistettava leikkialusta. Liittimien oikosulku ei ole sallittua. Tarkista säännöllisesti, että paristot eivät vuoda. Älä heitä käytettyjä paristoja talousjätteeseen, vain toiminta ne vain asiankuuluvuin keräyspisteisiin tai ongelmajätepaikkaan.

HU

Csak a megadott elemeket szabad használni. A nem tölthető elemek töltése tilos. A tölthető elemeket csak felnőttek felügyelete mellett szabad tölteni. A feltölthető elemeket ki kell venni a játékból a töltés előtt. Nem egyforma típusú elemek, vagy új és használt elemek együtt nem használhatók. Az elemeket a megfelelő polaritással kell behelyezni. A lemerült elemeket ki kell venni a játékból. A csatlakozó kapcsokat nem szabad rövidre zární. Rendszeresen ellenőrizni kell, hogy az elemek nem folynak-e. A használt elemeket nem szabad a háztartási szeméttel dobni, hanem le kell adni egy gyűjtőhelyen vagy veszélyes hulladék állomáson.

CZ

Používejte pouze uvedené baterie. Baterie, které není možno dobíjet, nesmějí být nabíjeny. Nabíjecí baterie smíjí být nabíjeny pouze pod dohledem dospělých osob. Nabíjecí baterie musejí být před nabíjením vyjmuty z hračky. Různé typy baterií nebo nové a použité baterie nesmějí být použity společně. Je nutno vložít baterie se stejnou polaritou. Prázdné baterie je nutno z hračky vyndat. Připojovací svorky nesmějí být spojeny nakrátko. Pravidelně kontrolujte, zda baterie nevytékají. Použité baterie neházejte do domovního odpadu, pouze je odevzdejte na stávající sběrná místa nebo stanovíte pro nebezpečný odpad.

EE

Kasutage ainult lubatud patareisid. Laadimisvõimaluseta patareisid on keelatud laadida. Laadimisvõimalusega patareisid tohib laadida ainult täiskasvanud isiku järelevalve all. Laadimisvõimalusega patareid tuleb enne laadimise alustamist märguasa seest välja võtta. Ärge kasutage korraga erinevat tüüpi või uusi ja kasutatud patareisid. Jälgige patareide paigaldamisel õiget polarisust. Tühjad patareid tuleb märguasa seest välja võtta. Ühendusklemmide lühistamine on keelatud. Kontrollige patareisid regulaarselt, et nad ei eraldaks vedelikku. Ärge visake



kasutuskõlbmatuid patareisid majapidamisprügi hulka, vaid andke need vastavatesse kogumiskohtadesse või ohtrike jäätmete kogumispunktesse.

**LV** Izmantot tikai norādītās baterijas. Neuzlādēt baterijas, kuras nedrīkst atkārtoti uzlādēt. Uzlādējamas baterijas drīkst uzlādēt tikai pieaugušo uzraudzībā. Uzlādējamas baterijas pirms uzlādēšanas izņem no transportlīdzekļa. Neizmantot kopā atšķirīgus bateriju tipus vai jaunas un lietotas baterijas. Ievietojot baterijas, ievērot polaritāti. Tukšās baterijas no rotāļietas jāizņem. Pieslēguma spailes nedrīkst saslēgt īslēgumā. Regulāri pārbaudīt, vai baterijas nav iztecējušas. Lietotas baterijas neizmet kopā ar sadzīves atkritumiem, bet gan esošajās bateriju savākšanas vietās vai speciālā atkritumu izvešanas vietā.

**LT** Naudoti tik nurodytas baterijas. Vienkartinių baterijų įkrauti negalima. Daugkartinio naudojimo baterijos turi būti įkraunamos suaugusiųjų priežiūroje. Prieš įkraunant daugkartinio naudojimo baterijas, jas reikia išimti iš žaislo. Negalima kartu naudoti skirtingų tipų, arba naujų ir naudotų baterijų. Baterijas reikia išdėti, atsižvelgiant į teisingą poliškumą. Išsikrovusias baterijas reikia išimti iš žaislo. Negalima atlikti trumpo jungiamųjų gnybtų jungimo. Reguliariai tikrinti ar baterijos nėra išsiverėję. Naudotų baterijų negalima išmesti kartu su buitinėmis atliekomis. Jas reikia atiduoti į esamas surinkimo vietas arba į pavojingų atliekų surinkimo aikštelę.

**SI** Uporabljajte le navedene baterije. Baterij, ki niso namenjene za polnjenje, ni dovoljeno polniti. Baterije, ki se jih sme polniti, je dovoljeno polniti le pod nadzorom odraslih oseb. Pred polnjenjem je baterije, ki se lahko polnijo, potrebno vzeti iz igrače. Skupaj ni dovoljeno uporabljati različnih vrst baterij ali novih in rabljenih baterij. Baterije je potrebno vstaviti pravilno obrnjene – s pravilno polariteto. Prazne baterije je potrebno vzeti iz igrače. Na priključnih sponkah ni dovoljeno povzročati kratkega stika. Redno preverjajte, ali baterije ne iztekajo. Izrabljenih baterij ne odlagajte med gospodinjinske odpadke, ampak jih oddajte na zbirnih mestih oz. na zbirališču posebnih odpadkov.

**SK** Používajte len uvedené batérie. Batérie, ktoré nie sú nabíjateľné, sa nesmú nabíjať. Nabíjateľné batérie sa smú nabíjať len pod dohľadom dospelých osôb. Nabíjateľné batérie je potrebné pred nabíjaním vybrať z hračky. Nerovnaké typy batérií alebo nové a použité batérie sa nesmú spoločne používať. Batérie sa musia vložiť so správnou polaritou. Prázdne batérie sa musia z hračky vybrať von. Prípojujúce svorky sa nesmú skratovať. Batérie pravidelne kontrolujte, či nevytekajú. Opotrebované batérie nevyhadzujte do domového odpadu, ale ich odovzdajte na existujúcich zberných miestach alebo na skládke špeciálneho odpadu.

**PL** Stosować tylko wskazane baterie. Zwykłe baterie, nie nadające się do powtórnego ładowania, nie mogą być ładowane. Baterie nadające się do powtórnego ładowania (akumulatory) mogą być ładowane tylko pod kontrolą osób dorosłych. Przed ładowaniem baterie-akumulatory należy wyjąć z zabawki. Nie stosować równocześnie baterii różnych typów ani baterii nowych wraz z używanymi. Podczas zakładania baterii zwrócić uwagę na ich prawidłową polaryzację. Rozładowane baterie usunąć z zabawki. Nie zwracać zaciwków. Regularnie sprawdzać, czy baterie

nie wyciekają. Zużytych baterii nie wyrzucać do kosza na śmieci, tylko oddać w odpowiednich punktach zbiórki lub wrzucić do przeznaczonych do tego celu specjalnych pojemników.

**TR** **CY** Yalnızca belirtilen pilleri kullanınız. Şarj edilemeyen piller şarj edilememelidir. Şarj edilebilir piller yalnızca yetiştirkinlerin gözetiminde şarj edilmelidir. Şarj edilebilir piller, şarj edilmeden önce oyuncak içerisinde çıkartılmaldır. Türleri birbirinden farklı piller veya yeni ve eski pilleri bir arada kullanmayınız. Piller kutupları doğru olacak şekilde yerleştirilmelidir. Biten piller oyuncak içerisinde çıkartılmaldır. Bağlantı klemensleri kisa devre yapılmamalıdır. Düzenli aralıklarla pillerin akım akımadıklarını kontrol ediniz. Kullanılmış pilleri ev çöplüne atmayınız, yalnızca özel toplama yerlerine atınız veya özel atık merkezine ulaştırınız.

**GR** **CY** Να χρησιμοποιείτε μόνο μπαταρίες του τύπου που σας υποδεικνύουν οι πληροφορίες ή αντίστοιχες. Ποτέ μην επαναφορτίζετε ή επαναφορτιζόμενες μπαταρίες. Οι επαναφορτιζόμενες μπαταρίες πρέπει να επαναφορτίζονται πάντα από ενήλικα. Αφαιρέτε τις επαναφορτιζόμενες μπαταρίες από την ηλεκτρονική μονάδα του παιχνιδιού πριν τις επαναφορτίσετε. Μην συνδυάζετε μπαταρίες διαφορετικών τύπων, π.χ. αλκαλικές ή επαναφορτιζόμενες με απλές, ή παλιές με καινούριες. Τοποθετείστε τις μπαταρίες με την σωστή πολικότητα. Όταν αδειάσουν οι μπαταρίες πρέπει να απομακρύνονται από το παιχνίδι. Ποτέ μη βραχυκυκλώσετε τους πόλους. Πάντα να ελέγχετε τις μπαταρίες για τυχόν διαρροές. Μην πετάτε ποτέ στα οικιακά απορρίμματα τις παλιές μπαταρίες, παρά μόνο σε ειδικούς κάδους ανακύκλωσης με την αντίστοιχη ένδειξη. Για τον κατάλληλο τρόπο ανακύκλωσης, παρακαλούμε επικοινωνήστε με τους τοπικούς φορείς.

**RO** Se vor folosi doar bateriile specificate. Bateriile fără reincărcare nu au voie să se încarce. Bateriile reincărcabile se vor încărca doar sub supravegherea adulților. Bateriile reincărcabile se scot din jucărie înainte de încărcare. Nu este permisă utilizarea împreună a bateriilor de tipuri diferite sau a bateriilor noi cu cele vechi. Bateriile trebuie introduse cu polaritatea corectă. Bateriile descărcate trebuie scoase din jucărie. Bornele nu au voie să fie scurtcircuitate. Bateriile trebuie verificate în mod regulat să nu prezinte scurgeri. Bateriile consumate nu se aruncă la deșeurile menajere, ci se predau la centrele existente de colectare sau în locurile pentru deșeuri speciale.

**BG** Използвайте само посочените батерии. Непредръзначени за зареждане батерии не бива да бъдат зареждани. Зареждащите се батерии трябва да бъдат зареждани само под надзора на възрастни. Зареждащите се батерии се изваждат от играчката, преди да се поставят за зареждане. Не използвайте заедно нееднакви модели батерии и нови и употребявани батерии не бива да се използват заедно. Поставяйте батериите, обръщайки внимание на правилния поляритет. Празните батерии трябва да бъдат изваждани от играчката. Свързващите клеми не трябва да бъдат давани на късо. Редовно проверявайте батериите за течове. Не изхвърляйте употребяваните батерии като домакински отпадък, а ги предавайте само на специално определени за това места или в дело за специални отпадъци.

**HR** Koristiti samo navedene baterije. Baterije za ponovno punjenje se ne smiju koristiti. Baterije za ponovno punjenje se smiju puniti samo pod nadzorom odraslih. Baterije za ponovno punjenje se prije punjenja moraju izvaditi iz igračke. Baterije raznih tipova ili nove i rabljene se ne smiju skupa upotrebljavati. Baterije se moraju umetnuti sa točnim polaritetom. Prazne baterije se moraju izvaditi iz igračke. Priključne stazaljke se ne smiju kratko spajati. Baterije redovito provjeravajte u svezi curenja. Istrošene baterije ne bacati u kućno smeće, već ove odnijeti na postojeća sabirna mjesta ili predati na jedno mjesto za posebno smeće.

**RU** Используйте только указанные батареи. Неперезаряжаемые батареи не следует заряжать. Перезаряжаемые батареи можно заряжать только под присмотром взрослых. Перед зарядкой перезаряжаемые батареи следует извлечь из игрушки. Различные типы батареек или новые и использованные батарейки не должны использоваться вместе. Батарейки следует вставить с учетом правильной полярности. Разряженные батарейки следует извлечь из игрушки. Не допускайте короткого замыкания соединительных клемм. Регулярно проверяйте батареи на предмет износа. Не выбрасывайте использованные батареи в бытовые отходы, а утилизируйте их только в соответствующих пунктах сбора или в месте для утилизации специальных видов отходов.

**CN** 只限使用规定的电池类型。非充电电池不能充电。充电电池只能在成年人监督下充电！充电电池在充电前应该从玩具中取出。不同类型的电池或新旧电池不能混用！电池应以正确的极性放入。用尽的电池应从玩具中取出。电源端子不得短路。用过的旧电池请勿随意丢弃在家庭垃圾中，而是放入回收站或者交给特殊处理处。（说明书上含有重要信息，请保留备用）

Aus  
Off  
Arrêt  
60 sec



Aus  
Off  
Arrêt  
30 sec



An / Aus  
On / Off  
Marche / Arrêt

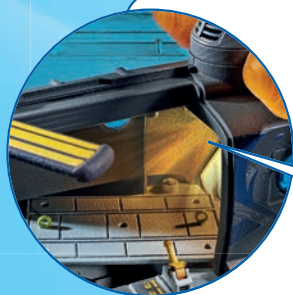

Aus  
Off  
Arrêt

2 sec



**DE AT CH LU BE ACHTUNG!** Das Spielzeug erzeugt Lichtblitze, die bei empfindlichen Personen Epilepsie auslösen können.

**US GB CA MT IE WARNING!** This toy produces flashes that may trigger epilepsy in sensitised individuals.

**FR CA BE LU CH ATTENTION!** Ce jouet crée des flashes lumineux susceptibles de déclencher des crises d'épilepsie chez certaines personnes.

**ES MX ¡ADVERTENCIA!** El juguete genera destellos de luz que, en personas sensibles, pueden provocar epilepsia.

**NL BE WAARSCHUWING!** het speelgoed veroorzaakt lichtflitsen, die bij gevoelige personen epilepsie kunnen veroorzaken.

**IT CH AVVERTENZA!** Il giocattolo genera lampi di luce che possono provocare epilessia nei soggetti sensibili.

**PT ATENÇÃO!** O brinquedo imite raios de luz que, em caso de pessoas sensíveis pode provocar epilepsia.

**DK ADVARSEL!** Dette legetøj frembringer lysglimt, der kan fremprovokere epileptiske anfald hos særlig følsomme mennesker.

**NO ADVARSEL!** Leketøyet fremkaller lynlys som kan utløse epilepsi hos ømfintlige personer.

**SE FI VARNING!** Den här leksaken avger ljusblixtar, som kan utlösa epilepsi hos känsliga personer.

**FI VAROITUS!** Lelu välkkyä ja voi aiheuttaa epilepsia-kohtauksen herkimille henkilöille.

**HU FIGYELMEZTETÉS!** A játékszer fényfelvillanásokat okoz, amely az arra érzékeny személyeknél epilepsziás rohamokat válthat ki!

**CZ UPOZORNĚNÍ!** Hračka vydává světelné záblesky, které mohou u citlivých osob vyvolat epilepsii.

**EE HOIATUS!** Mänguasi tekitab valgusvälgatusi, mis võivad tundlikel inimestel vallandada epileptilisi hoogusid.

**LV BRĪDINĀJUMS!** Rotaļlietai darbojoties, rodas gaismas zibšņi, kas var izraisīt epilepsijas lēkmi jutīgām personām.

**LT ĮSPĖJIMAS!** Žaislas generuoja šviesos blyksnius, kurie jautriems asmenims gali sukelti epilepsiją.

**SI OPOZORILO!** Igrača oddaja bliske, ki pri občutljivih osebah lahko lahko sprožijo epileptične napade.

**SK UPOZORNENIE!** Hračka vytvára záblesky svetla, ktoré môžu u citlivých osôb vyvolať epilepsiu.

**PL OSTRZEŻENIE!** Zabawka wytwarza błyski, które u osób wrażliwych mogą wywoływać napady epilepsji.

**TR CY DİKKAT!** Oyuncak, hassas kişilerde epilepsi nöbetine neden olabilecek ışık flaşları oluşturmaktadır.

**GR CY ΠΡΟΕΙΔΟΠΟΙΗΣΗ!** Το παιχνίδι παράγει αστραπιαίο φως που μπορεί να προκαλέσει επιληψία σε ευαίσθητα άτομα.

**RO AVERTISMENT!** Jucăria produce pulsuri de lumină care pot declanșa crize de epilepsie la persoanele sensibile.

**BG Внимание!** Играчката произвежда светкавици, които могат да предизвикат епилепсия при чувствителни лица.

**HR UPOZORENJE!** Igračka proizvodi bljeskove koji kod osjetljivih osoba mogu izazvati epilepsiju.

**RU Внимание!** игрушка генерирует вспышки света, которые могут вызвать эпилептический припадок у чувствительных людей.

**CN 警告!** 本玩具产生闪光, 在敏感者有导致癫痫发作的可能。



**DE AT CH LU BE Denken Sie an den Schutz der Umwelt!**

- Ihr Gerät enthält wertvolle Rohstoffe, die wieder verwertet werden können.
- Geben Sie Ihr Gerät deshalb bitte bei einer Sammelstelle Ihrer Stadt oder Gemeinde ab.

**GB MT IE Environment protection first!**

- Your appliance contains valuable materials which can be recovered or recycled.
- Leave it at a local civic waste collection point.

**FR LU CH Participons à la protection de l'environnement !**

- Votre appareil contient de nombreux matériaux valorisables ou recyclables.
- Confiez celui-ci dans un point de collecte pour que son traitement soit effectué.

**ES ¡¡ Participe en la conservación del medio ambiente !!**

- Su electrodoméstico contiene materiales recuperables y/o reciclables.
- Entréguelo al final de su vida útil, en un Centro de Recogida Específico o en uno de nuestros Servicios Oficiales Post Venta donde será tratado de forma adecuada.

**NL BE Samen het milieu beschermen!**

- Uw product bevat meerdere recycleerbare materialen
- Breng deze naar een afval-inzamelpunt.

**BE Participons à la protection de l'environnement!**

- Votre appareil contient de nombreux matériaux valorisables ou recyclables.
- Confiez celui-ci dans un point de collecte ou à défaut dans un centre service agréé pour que son traitement soit effectué.

**IT CH Partecipiamo alla protezione dell'ambiente!**

- Il vostro apparecchio è composto da diversi materiali che possono essere riciclati.
- Lasciatelo in un punto di raccolta o presso un Centro Assistenza Autorizzato.

**PT Protecção do ambiente em primeiro lugar!**

- O seu produto contém materiais que podem ser recuperados ou reciclados.
- Entregue-o num ponto de recolha para possibilitar o seu tratamento.

**DK Vi skal alle være med til at beskytte miljøet!**

- Apparatet indeholder mange materialer, der kan genvindes eller genbruges.
- Bring det til et specialiseret indsamlingssted for genbrug eller et autoriseret serviceværksted, når det ikke skal bruges mere.

**SE FI Var rädd om miljön!**

- Din apparat innehåller olika material som kan återanvändas eller återvinnas.
- Lämna den på en återvinningsstation eller på en auktoriserad serviceverkstad för omhändertagande och behandling.

**FI Huolehtikaamme ympäristöstä!**

- Laitteesi on varustettu monilla arvokkailla ja kierrätettävillä materiaaleilla.
- Toimita laitteesi keräyspisteeseen tai sellaiseen puuttuessa vaikka valtuutettuun huoltoekukseen, jotta laitteen osat varmasti kierrätetään.

**HU Első a környezetvédelem!**

- Az Ön terméke értékes újrahasznosítható anyagokat tartalmaz.
- Kérjük készülékét ne dobja ki, hanem adja le az erre a célra kijelölt gyűjtőhelyen.

**CZ Podílejme se na ochraně životního prostředí!**

- Váš přístroj obsahuje četné zhodnotitelné nebo recyklovatelné materiály.
- Svěťte jej sběrnému místu nebo, neexistuje-li, smluvnímu servisnímu středisku, kde s ním bude naloženo odpovídajícím způsobem.

**SI Sodelujmo pri varovanju okolja!**

- Vaš aparat vsebuje številne dele, ki imajo svojo vrednost ali jih je še mogoče uporabiti.
- Oddajte ga na mestu za zbiranje odpadkov ali pa na pooblaščenem servisu, da bo šel v predelavo.

**SK Podieľajme sa na ochrane životného prostredia!**

- Váš prístroj obsahuje čítne zhodnotiteľné alebo recyklovateľné materiály.
- Zverte ho sběrnému miestu alebo, ak neexistuje, zmluvnému servisnému stredisku, kde s ním bude naložené zodpovedajúcim spôsobom.

**PL Bierzmy czynny udział w ochronie środowiska!**

- Twoje urządzenie jest zbudowane z materiałów, które mogą być poddane ponownemu przetworzeniu lub recyklingowi.
- W tym celu należy je dostarczyć do wyznaczonego punktu zbiórki.

**GR CY Ας συμβάλλουμε κι εμείς στην προστασία του περιβάλλοντος!**

- Η συσκευή σας περιέχει πολλά αξιοποιήσιμα ή ανακυκλώσιμα υλικά.
- Παραδώστε την παλιά συσκευή σας σε κέντρο διαλογής ή σε ένα εξουσιοδοτημένο κατάστημα σέρβις.

**RO Țineți cont de protecția mediului!**

- Aparatul dvs. conține materii prime valoroase care pot fi revalorificate.
- Din acest motiv vă rugăm să predați aparatul dvs. la un centru de colectare din orașul sau comuna dvs.

**BG Мислете за околната среда!**

- Вашият уред съдържа ценни суровини, които могат да бъдат рециклирани.
- Затова върнете своя електроуред на специално място за събиране на такива отпадъци във Вашия град или община.

**RU Подумайте о защите окружающей среды!**

- Ваше устройство содержит ценное сырье, которое может быть переработано.
- Поэтому, пожалуйста, верните ваше устройство в пункт сбора в вашем городе или муниципалитете.

**CN 环保第一！设备含有可回收和可再循环的有价值的材料，将其放回当地的市政垃圾收集点。**

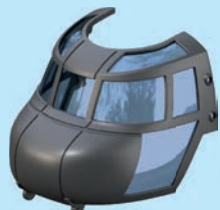

30 51 4883



30 65 8675



4x 30 09 0934

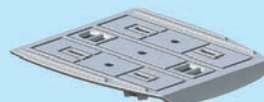

30 45 2183



30 63 9418



30 65 7518



30 81 6925



30 26 4270



30 88 1522



30 89 1350



30 23 0682



2x 30 89 6992



2x 30 26 4390



30 51 4873



30 09 4114



30 04 9880



30 63 9448



30 02 2894



30 63 9468



30 25 6252



30 20 5573



30 63 9458



30 00 4395



30 08 0504



30 00 4405



2x 30 23 7230



30 09 4020



30 03 0720



30 21 5252



30 09 0994



30 09 4144



30 65 8695

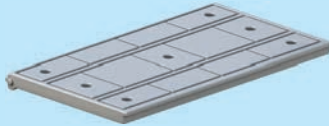

30 45 2943



30 63 9528

2x 30 20 9883



30 09 4094



2x 30 22 2183



2x 30 21 3450



3x 30 09 4044



4x 30 20 9950



2x 30 09 4084



2x 30 09 0944



30 27 8010



30 09 4134



30 05 5653



6x 30 09 4104



30 04 2582



30 09 4154



30 09 4124



4x 30 09 3820



30 23 1612



30 05 5192



30 07 0912



30 21 7172



2x 30 09 4074



4x 30 09 4064



2x 30 23 1712



2x 30 25 2343



8x 30 05 9984



8x 30 82 0980



2x 30 20 8443



4x 30 09 4054



FR  
DONNEZ  
OU  
RECYCLEZ



ASSOCIATION



MAGASIN



LIVRAISON



DÉCHÈTERIE

Adresses sur [quefairedemesdechets.fr](http://quefairedemesdechets.fr)

71149 + 71147



US

**NOTE:** This equipment has been tested and found to comply with the limits for a Class B digital device, pursuant to part 15 of the FCC Rules. These limits are designed to provide reasonable protection against harmful interference in a residential installation. This equipment generates, uses and can radiate radio frequency energy and, if not installed and used in accordance with the instructions, may cause harmful interference to radio communications. However, there is no guarantee that interference will not occur in a particular installation. If this equipment does cause harmful interference to radio or television reception, which can be determined by turning the equipment off and on, the user is encouraged to try to correct the interference by one or more of the following measures:

- Reorient or relocate the receiving antenna.
- Increase the separation between the equipment and receiver.
- Connect the equipment into an outlet on a circuit different from that to which the receiver is connected.
- Consult the dealer or an experienced radio/TV technician for help.

**PLAYMOBIL USA, INC.**

26 Commerce Drive  
Cranbury, NJ 08512  
Phone 1-800-752-9662 or 609-395-5566  
Email: [service@playmobilusa.com](mailto:service@playmobilusa.com)

**Caution:** Changes or modifications not expressly approved by the party responsible for compliance could void the user's authority to operate the equipment.

US

This device complies with Part 15 of the FCC Rules. Operation is subject to the following two conditions:

- (1) This device may not cause harmful interference, and
- (2) this device must accept any interference received, including interference that may cause undesired operation.

CA

CAN ICES-3 (B)/NMB-3(B)

Cet équipement est conforme à la Section 15 des règlements de la FCC. Son fonctionnement est soumis aux deux conditions suivantes:

- (1) Cet équipement ne peut causer d'interférence nuisible, et
- (2) cet équipement doit pouvoir fonctionner même s'il capte de l'interférence, incluant celle pouvant provoquer un fonctionnement indésirable.



71144



71149



71147



71146



©2023 geobra Brandstätter Stiftung & Co. KG  
Brandstätterstr. 2-10 • 90573 Zirndorf, Germany  
No. 30 82 2306 07-23