

# NOVELMORE

playmobil



71023

# NOVEL MORE

In den schroffen Wüsten von Sal'ahari Sands sind uralte Ruinen stumme Zeugen einer längst vergangenen Zeit. Nur das Vorkommen einer mysteriösen grünen Substanz gibt nach wie vor Rätsel auf und bietet allen Reisenden einen guten Grund von einem Abstecher nach Sal'ahari Sands abzusehen.

Als sich der Konflikt in Violet Vale zuspitzt, sendet der dunkle Zauberer Umbrathor seinen Gehilfen nach Sal'ahari Sands, auf die Suche nach einem Tempel, in dem die Macht verborgen liegt ein schlummerndes Volk wieder zum Leben zu erwecken.

Eine Armee untoter Skelettkrieger erwacht – unkontrollierbar und bereit, die fünf Reiche zu zerstören.

Können Dario, Gwynn und Arwynn dem bösen Zauberer und der Skelettarmee gemeinsam mit Timithor Einhalt gebieten? Und welche Rolle spielen dabei die Ahari - ein kleines, eher zurückgezogenes, aber an die schroffen Gegebenheiten angepasstes Wüstenvolk, welches gerne unter sich bleibt und experimentiert, zum Beispiel mit Skarpium, dem Skorpiongift.

In the harsh deserts of Sal'ahari Sands, ancient ruins are silent witnesses to a time long gone.

Only the presence of a mysterious green substance still poses a mystery and gives all visitors a good reason to avoid a detour through the Sal'ahari Sands.

As the conflict in Violet Vale comes to a head, the dark sorcerer Umbrathor sends his assistant to Sal'ahari Sands on a quest for a temple that holds the power to bring slumbering people back to life. An army of undead skeleton warriors awakens – uncontrollable and ready to destroy the five realms.

Can Dario, Gwynn, and Arwynn join Timithor in stopping the evil wizard and the skeleton army? And what role does the Ahari play in this – a small, rather reclusive desert people adapted to the harsh conditions, who like to keep to themselves and experiment with items like scarpium, a scorpion poison.

Dans le désert sauvage de Sal'ahari Sands, d'anciennes ruines sont les témoins silencieux d'une époque passée...

Seule la présence d'une étrange substance verte reste un mystère et offre à tous les voyageurs une bonne raison de ne pas faire le détour par Sal'ahari Sands.

Alors que le conflit dans Violet Vale s'intensifie, le sombre sorcier Umbrathor envoie son assistant à Sal'ahari Sands à la recherche d'un temple qui aurait le pouvoir de ramener les anciens peuples à la vie. Une armée de guerriers squelettes morts-vivants se réveille, incontrôlable et prête à détruire les cinq royaumes.

Dario, Gwynn et Arwynn peuvent-ils rejoindre Timithor pour arrêter le sorcier maléfique et l'armée de squelettes ? Et quel rôle jouent les Ahari – un petit peuple du désert, plutôt reclus mais adapté aux conditions sauvages. Ils aiment rester entre eux et faire des expériences, par exemple avec le scarpium, le poison du scorpion.

En el hostil desierto de Sal'ahari Sands, las antiguas ruinas son testigos silenciosos de un tiempo ya pasado...

Sólo la presencia de una misteriosa sustancia verde sigue siendo un misterio y ofrece a todos los viajeros una buena razón para no desviarse por Sal'ahari Sands.

A medida que el conflicto en Violet Vale llega a su punto álgido, el mago oscuro Umbrathor envía a su ayudante a Sal'ahari Sands en busca de un templo que contiene el poder de devolver a la vida a un pueblo dormido. Un ejército de esqueletos guerreros no muertos despierta, incontrolable y listo para destruir los cinco Reinos.

¿Podrán Dario, Gwynn y Arwynn unirse a Timithor para detener al malvado mago y al ejército de esqueletos? Y qué papel juegan los Ahari en todo esto: un pequeño pueblo del desierto, bastante solitario, pero adaptado a las duras condiciones, al que le gusta mantenerse al margen y experimentar, por ejemplo, con el Scarpium, el veneno de los escorpiones.





## SWORD

**Kampfkunsttrainerin** • möchte sich immer wieder selbst übertreffen • stumm, aber versteht Giza blind

**Fight trainer** • always wants to surpass herself • silent, but understands Giza blindly

**Entraîneur de combat** • veut toujours se surpasser • muette, mais comprend Giza aveuglément

**Entrenadora de lucha** • siempre quiere superarse a sí misma • callada, pero entiende a Giza ciegamente



## TALUS

**Skorpionjäger** • gewieft • macht sich die Elemente für die Ahari zu Nutze

**Scorpion hunter** • cunning • takes advantage of the elements for the Ahari

**Chasseur de scorpions** • rusé • tire parti des éléments pour aider les Ahari

**Cazador de escorpiones** • astuto • aprovecha los elementos para el Ahari



**GWYNN**

Erste Ritterin und Co-General der Armee • mutig • gewitzt

First female knight and co-general of the army • brave • witty.

Première femme chevalier et co-générale de l'armée • courageuse • vive

Primera mujer caballero y co-general del ejército • valiente • ingeniosa



**DARIO**

Genialer Erfinder • etwas schüchtern, aber setzt alles für Novelmore und seine Freunde in Bewegung

Brilliant inventor • a little shy but goes out of his way for Novelmore and his friends

Inventeur brillant • un peu timide mais qui se donne du mal pour Novelmore et ses amis

Brillante inventor • un poco tímido pero se desvive por Novelmore y sus amigos



**ARWYNN**

Prinz von Novelmore • abenteuerlustig • kämpft für das Gute

Prince of Novelmore • adventurous soul • fights for his cause

Le prince de Novelmore • âme aventureuse • se bat pour la bonne cause

Príncipe de Novelmore • alma aventurera • lucha por la buena causa

**NEU new**  
Nouveau  
nuevo

Aufbauen leicht gemacht mit nummerierten Tüten.  
Viel Spaß mit deinem neuen PLAYMOBIL-Spielzeug!

Set-up made easy with numbered bags.  
Have fun with your new PLAYMOBIL toy!

Simplicité de montage avec les sachets numérotés.  
Amuse-toi avec tes nouveaux PLAYMOBIL!

El montaje es más fácil  
con las bolsas numeradas.  
¡Diviértete con tu nuevo  
juguete de PLAYMOBIL!



## WARNING: CHOKING HAZARD

Contains a small ball and small parts.  
Not for children under 3 years.

”Ne concerne que les USA“

Wichtige Unterlagen, bitte sorgfältig aufbewahren!  
Important: Please keep these instructions for future reference!  
Documents importants, à conserver soigneusement!  
¡Por favor, guarde estas instrucciones para el futuro!  
Belangrijke documenten, bewaar deze zorgvuldig!

Abbildungen können vom Original abweichen.  
Product may differ from image shown.  
Les illustrations peuvent différer de l'original.  
Las ilustraciones pueden diferir del original.  
Afbeeldingen kunnen verschillen van het werkelijke artikel.

Serviceadressen finden Sie in allen  
PLAYMOBIL-Prospekten

Addresses of Customer Service Depart-  
ments are shown in all PLAYMOBIL  
catalogues

L'adresse du service consommateurs  
est indiquée dans tous les catalogues  
PLAYMOBIL

Troverete gli indirizzi dei centri di  
assistenza in tutti i cataloghi PLAYMOBIL

UK-Importer:  
**Playmobil UK Ltd.**  
Regency House  
1 Miles Gray Road  
Basildon  
Essex  
SS14 3RW  
UK

**UK  
CA**

In alle PLAYMOBIL catalogi vindt u  
het adres van onze klantendienst.

Las Direcciones de los Departamentos  
de Servicio al Consumidor se encuentran  
en todos los catálogos PLAYMOBIL

Η διεύθυνση του Γραφείου Εξυπηρέτησης  
Καταναλωτών PLAYMOBIL βρίσκεται σε  
όλους τους καταλόγους PLAYMOBIL.

pronounced: plāy-mō-bēē!





+

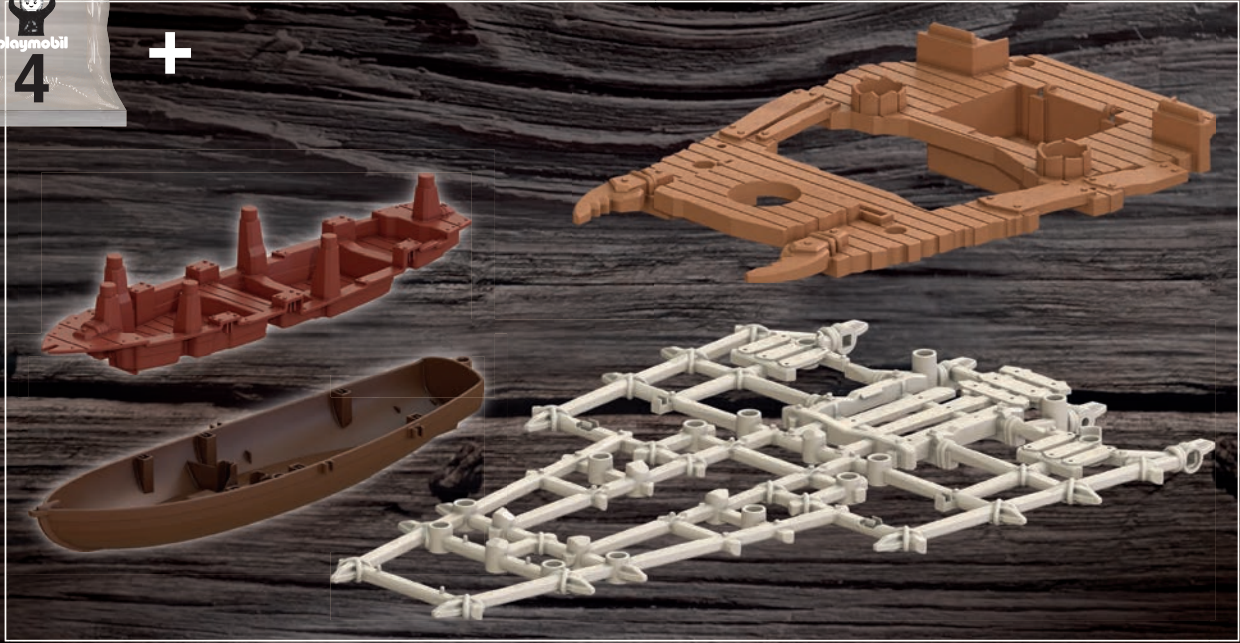

1

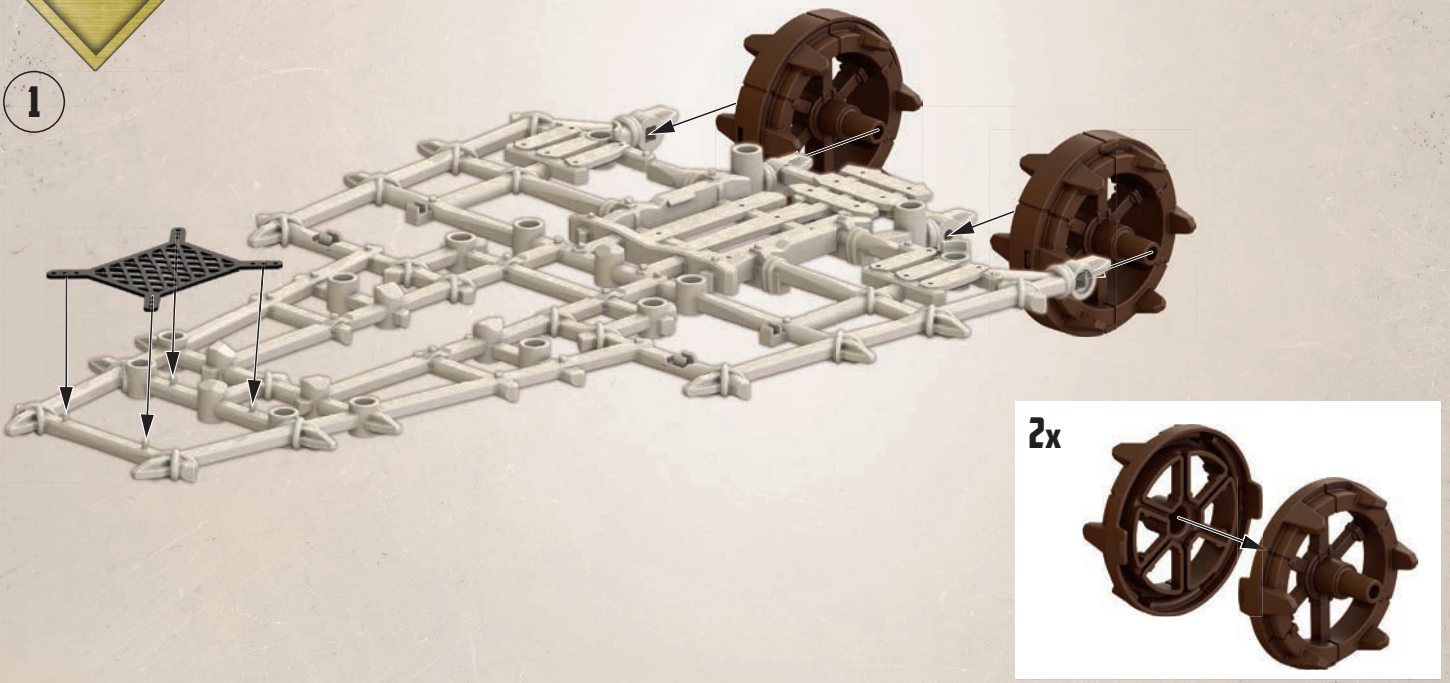

2

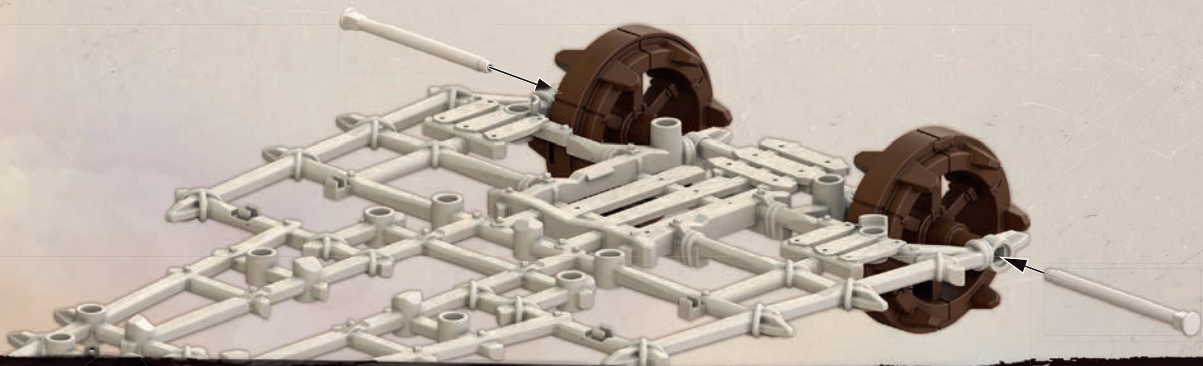



2



3

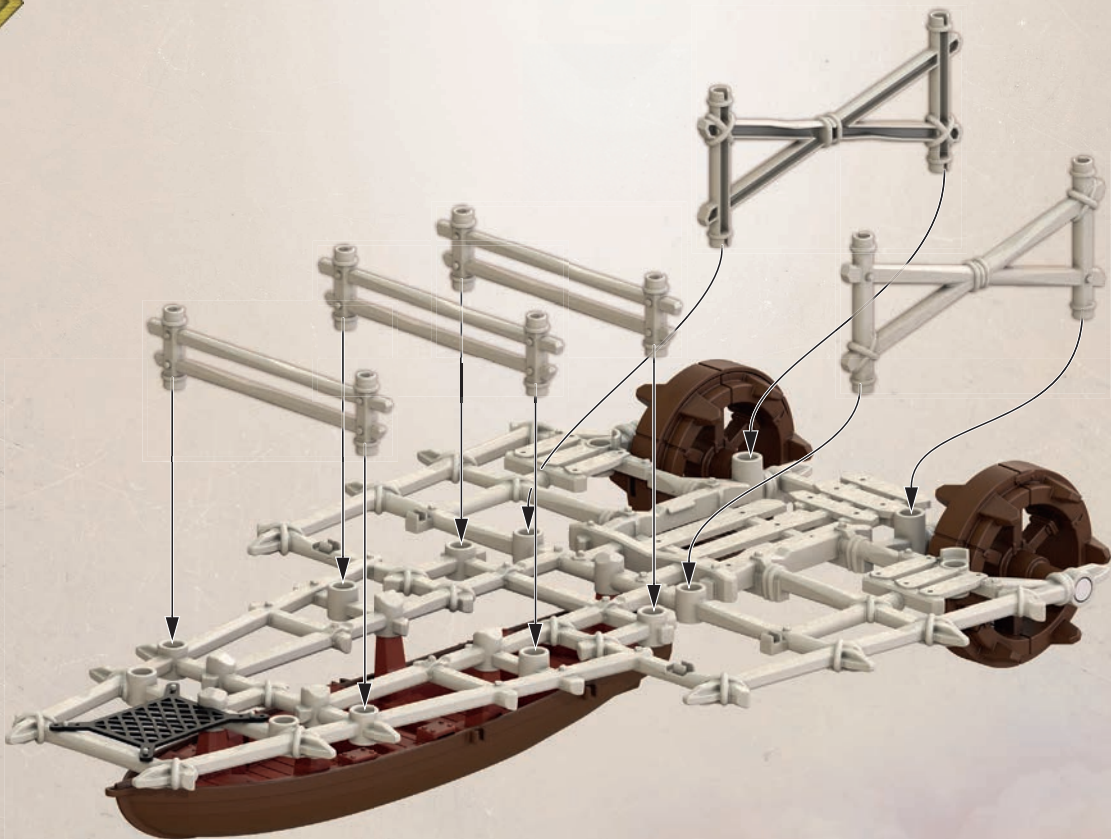

4

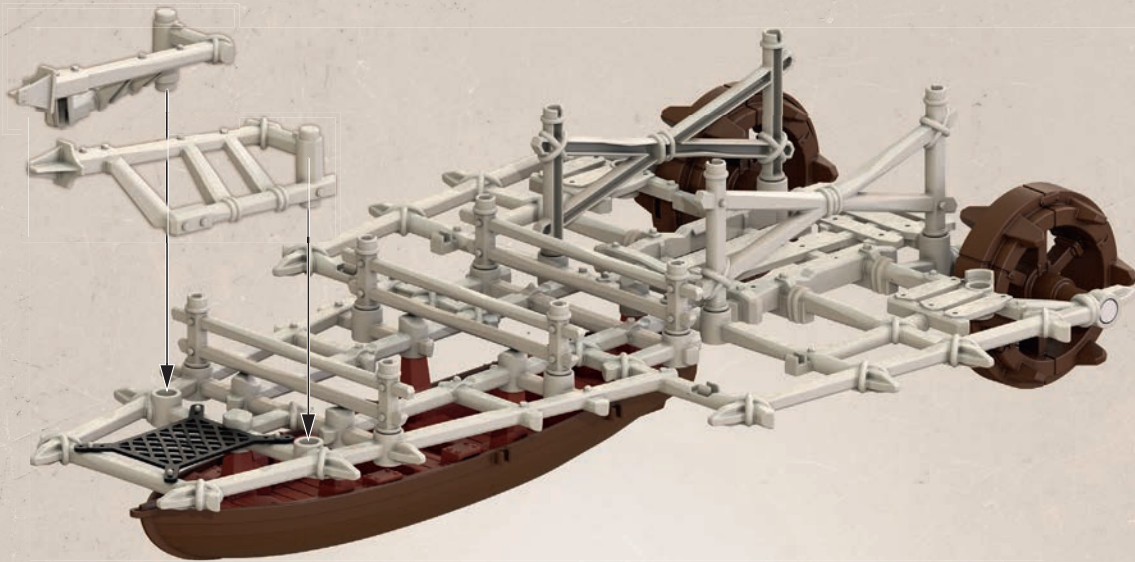

5

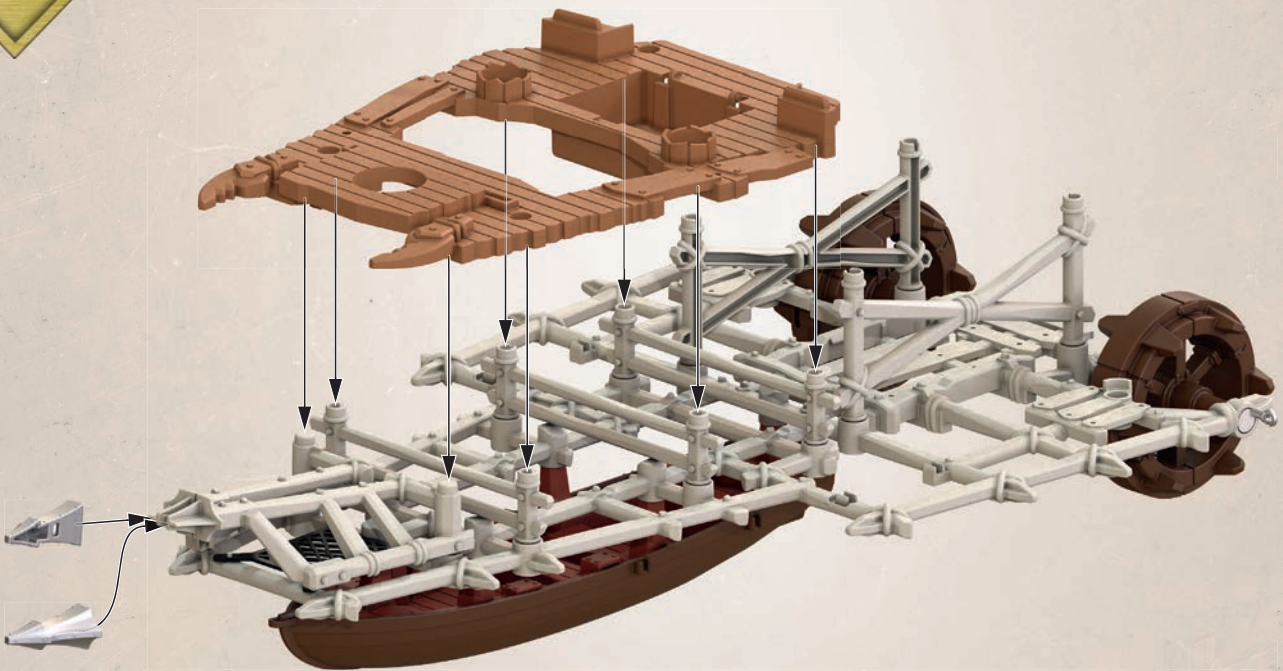



+

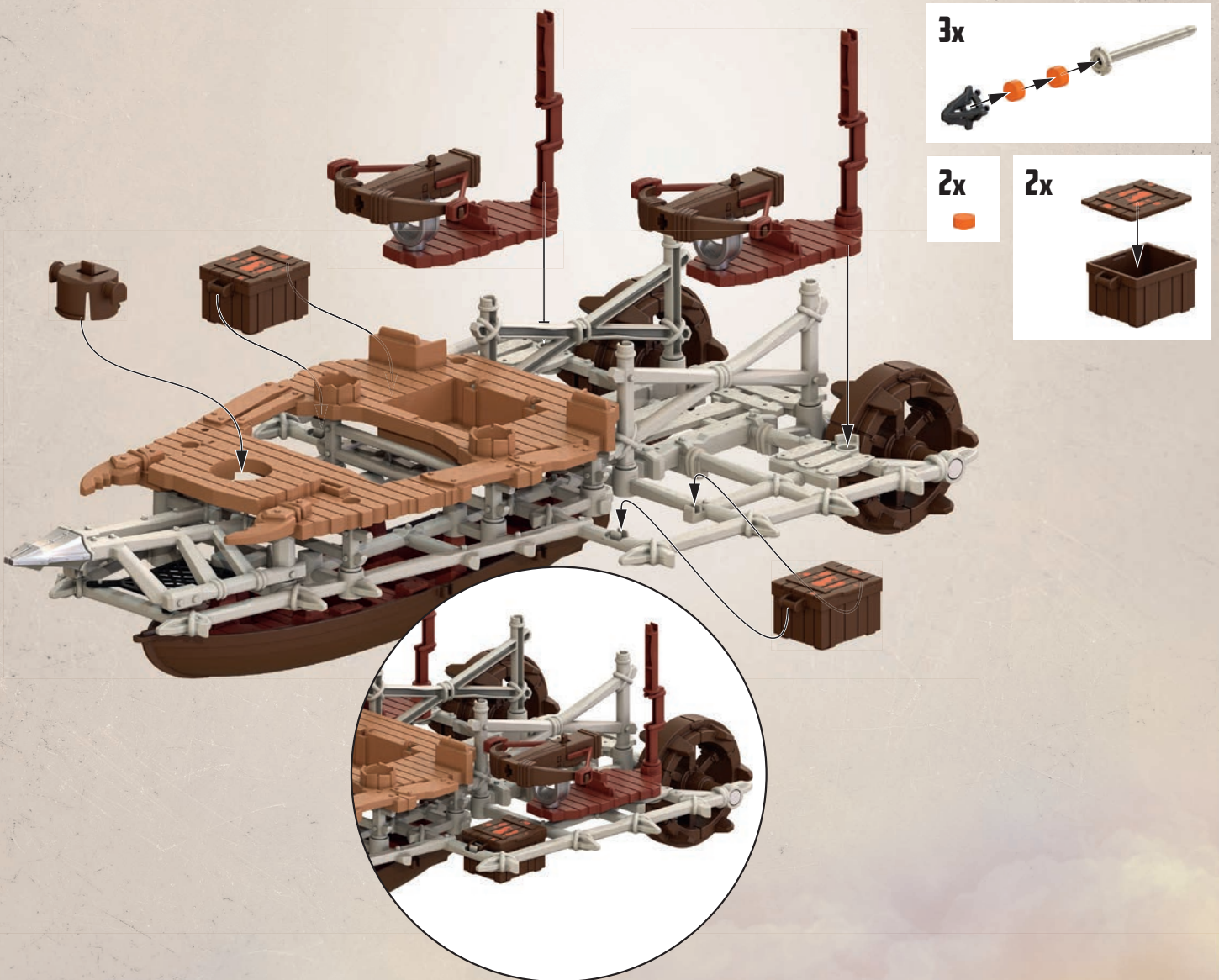
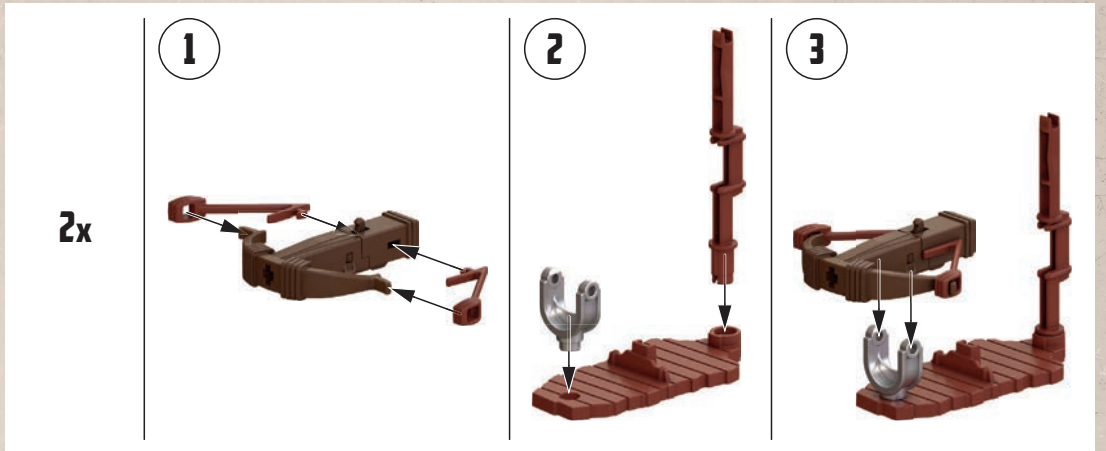

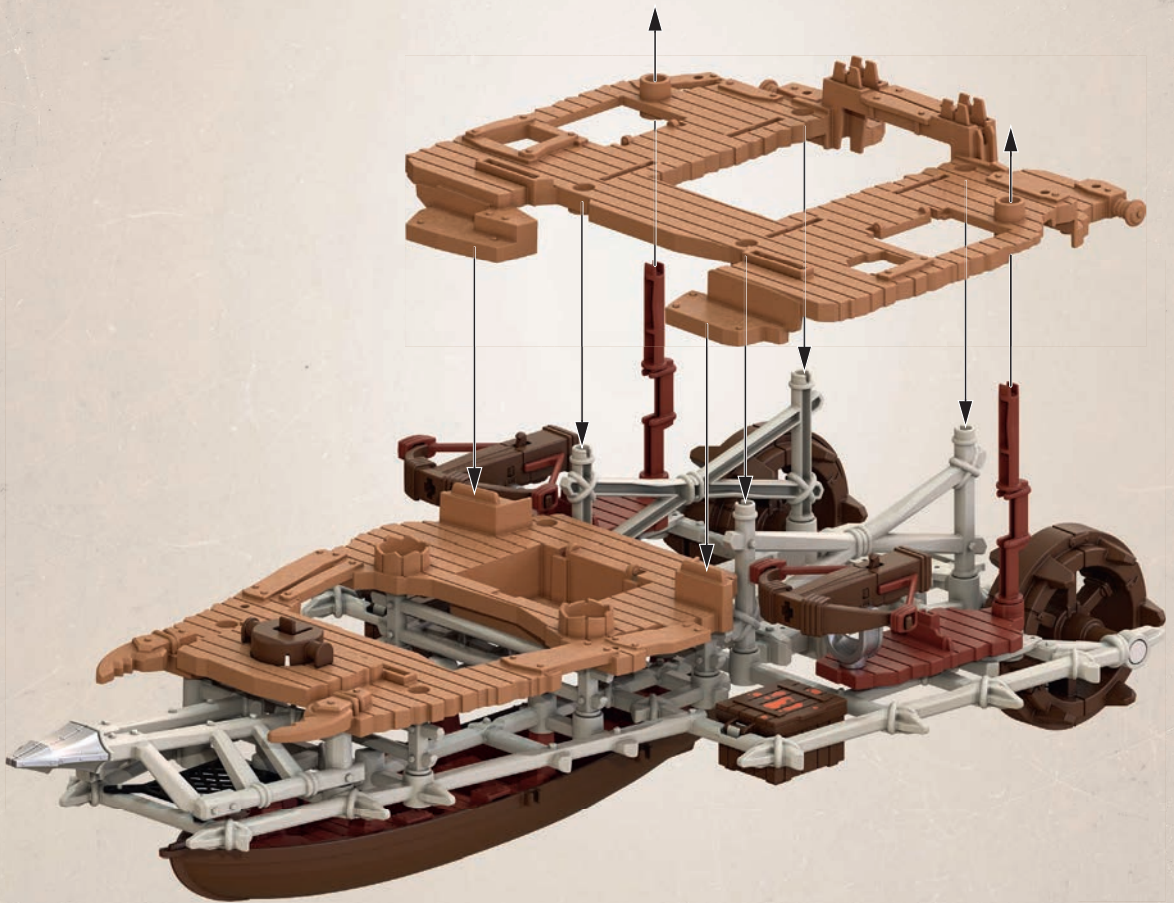
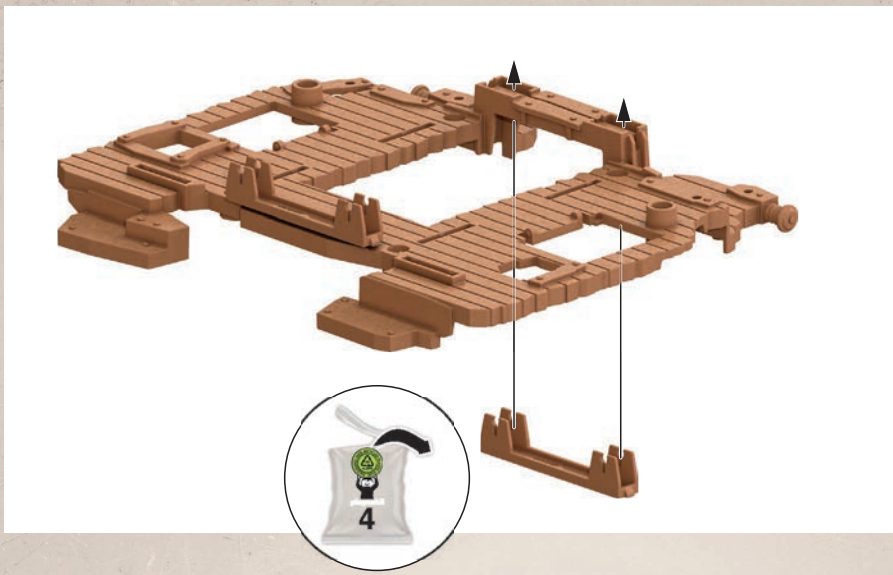

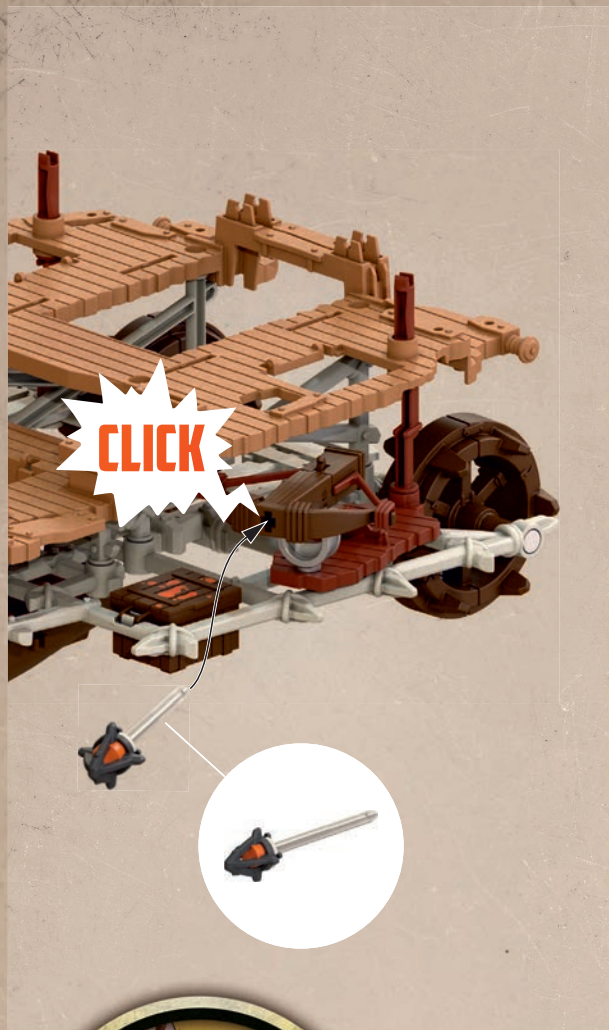

- DE AT CH LU BE ACHTUNG!** Nur mitgelieferte PLAYMOBIL Geschosse verwenden. Nicht auf Augen oder Gesicht zielen.
- US GB CA MT IE WARNING!** Only use the PLAYMOBIL projectiles supplied. Do not aim at eyes or face.
- FR CA BE LU CH ATTENTION!** Seulement utiliser les projectiles PLAYMOBIL fournis. Ne pas viser les yeux ou le visage.
- ES MX ¡ADVERTENCIA!** Utiliza únicamente los proyectiles PLAYMOBIL suministrados. No apuntar a los ojos ni a la cara.
- NL BE WAARSCHUWING!** Uitsluitend meegeleverde PLAYMOBIL delen gebruiken. Niet op ogen of gezicht richten.
- IT CH AVVERTENZA!** Usare soltanto i proiettili PLAYMOBIL in dotazione. Non mirare agli occhi o al viso.
- PT ATENÇÃO!** Usar apenas os projécteis PLAYMOBIL juntamente fornecidos. Não apontar para os olhos ou face.
- DK ADVARSEL!** Anvend kun de medfølgende PLAYMOBIL projektiler. Sigt ikke mod øjne eller ansigt.
- NO ADVARSEL!** Benytt kun PLAYMOBIL prosjektil som leveres med. Sikt ikke på ansikt eller øyne.
- SE FI WARNING!** Använd endast medlevererade PLAYMOBIL-skott. Ei saa kohdistaa suoraan silmiin tai kasvoihin.
- FI VAROITUS!** Käytä vain mukana toimitettuja PLAYMOBIL-ammuksia. Älä tähtää päin silmiä tai kasvoja.
- HU FIGYELMEZTÉTÉS.** Csak a csomagban található PLAYMOBIL lövedékeket szabad használni. Tilos szemre vagy arcra célozni.
- CZ UPOZORNĚNÍ!** Používejte pouze střely PLAYMOBIL, které jsou součástí dodávky. Nemířte na oči nebo na obličej!
- EE HOIATUS!** Kasutage ainult kaasaantud PLAYMOBIL'i laskemoona. Ära sihi silmadesse ega näkku.
- LV BRĪDINĀJUMS!** Izmantot tikai PLAYMOBIL piegādes komplektā iekļautos šāviņus. Nevērst pret acīm vai seju.
- LT ĮSPĖJIMAS!** Naudokit tik pridedamus PLAYMOBIL šaudmenis. Netaikyti į akis arba veidą.
- SI OPOZORILO!** Uporabljajte le priložene PLAYMOBIL-ove kroglice. Ne merite v oči ali obraz.
- SK UPOZORNENIE!** Používajte len náboje dodávané spolu so sadou PLAYMOBIL. Nemieriť do očí alebo do tváre.
- PL OSTRZEŻENIE!** Stosować tylko załączone PLAYMOBIL - kule / pociski. Nie celować w oczy i twarz.
- TR CY ΔΙΚΚΑΤ!** Sadece birikte verilen PLAYMOBIL mermileri kullanınız. Göze veya yüze doğru tutmayınız.
- GR CY Προειδοποίηση!** Να χρησιμοποιούνται αποκλειστικά τα βλήματα της PLAYMOBIL που περιέχονται στη συσκευασία. Μη μην γίνεται στόχευση στα μάτια ή στο πρόσωπο.
- RO AVERTISMENT!** Se folosesc doar proiectilele incluse PLAYMOBIL. Nu se țintește în ochi sau în față.
- BG Внимание!** Използвайте само приложени PLAYMOBIL снаряди. Не насочвайте към очите и лицето.
- HR UPOZORENJE!** Upotrijebiti samo od strane PLAYMOBIL-a isporučene projektili. Ne ciljati u oči ili lice.
- RU Внимание!** Используйте только поставляемые в комплекте снаряды PLAYMOBIL. Не цельтесь в глаза или в лицо.
- CN 警告!** 仅能用PLAYMOBIL 弹射物, 请勿瞄准眼睛或脸。



+

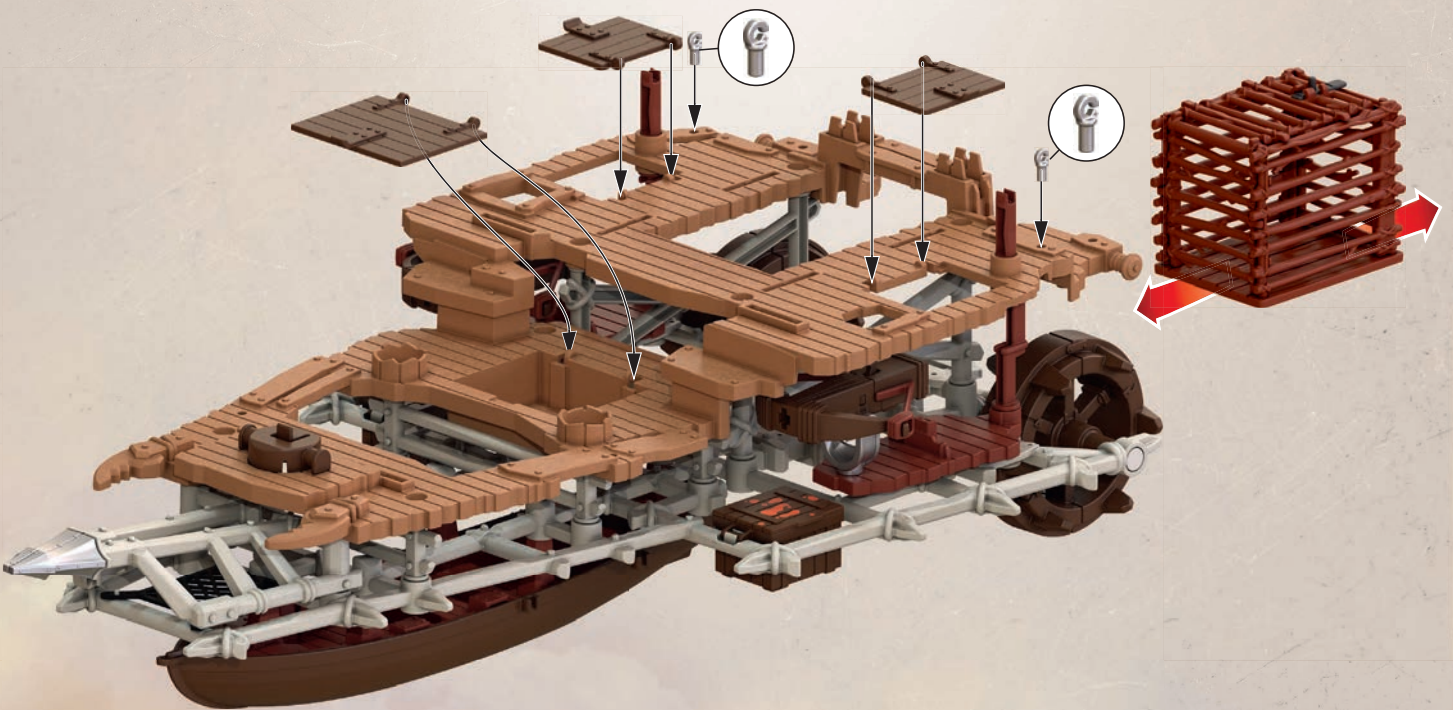
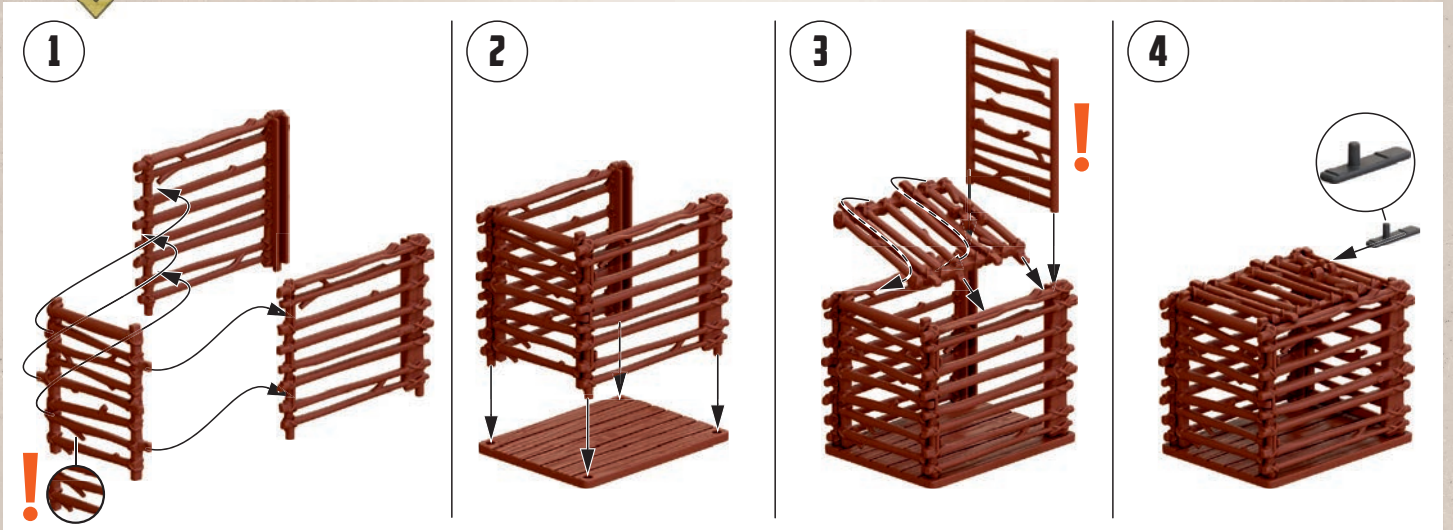

2

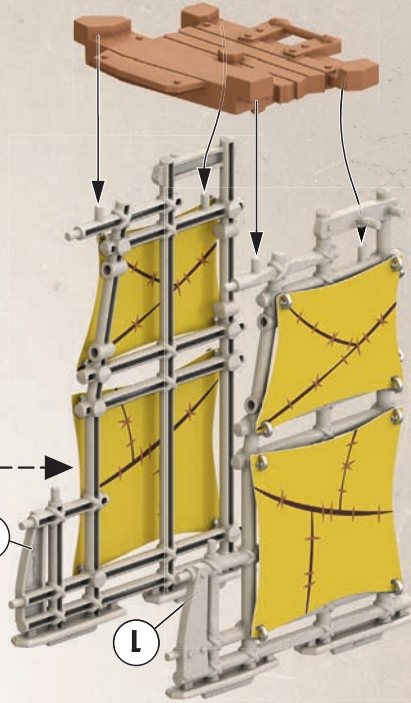
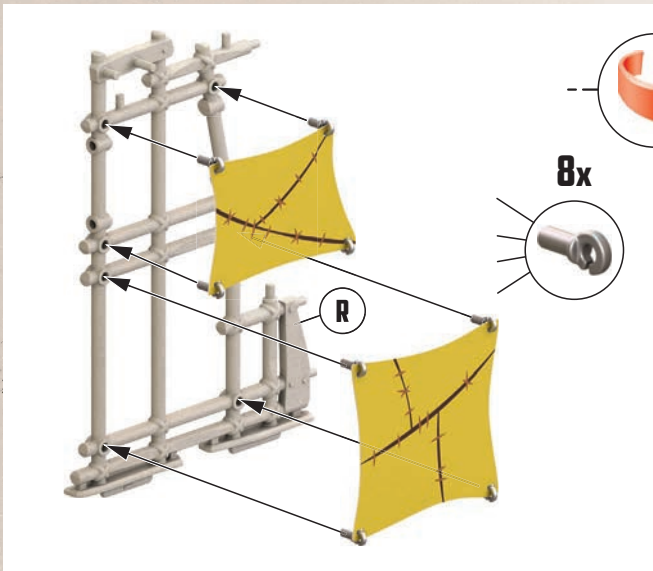
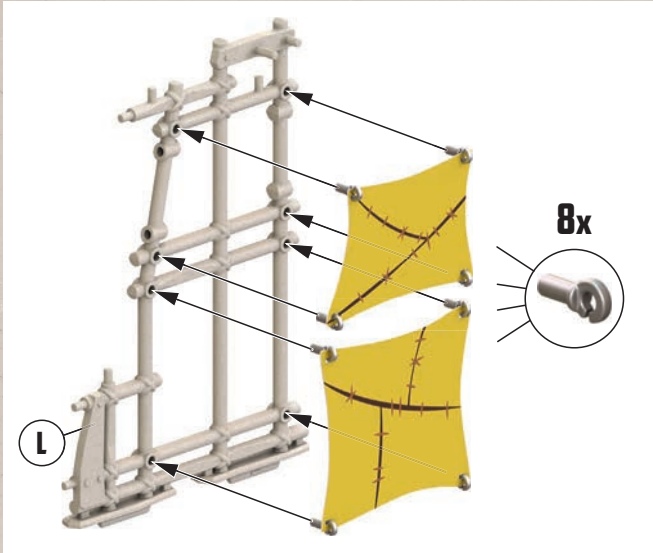

3

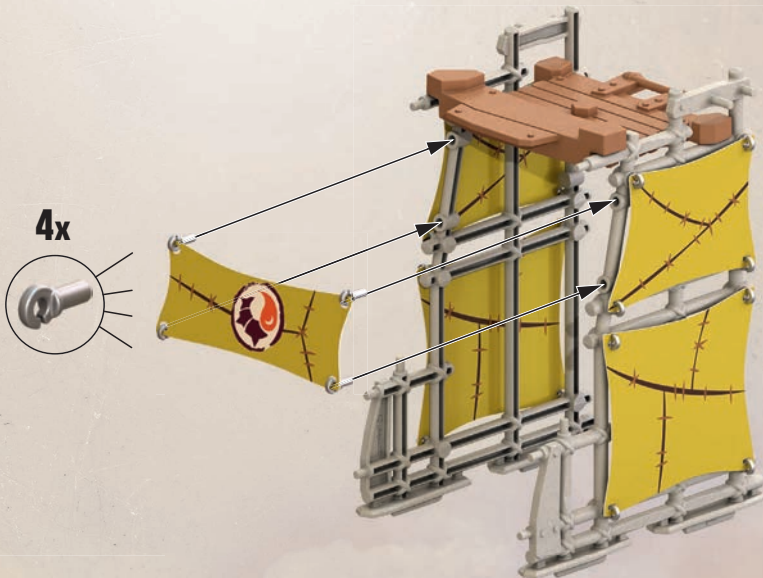

4

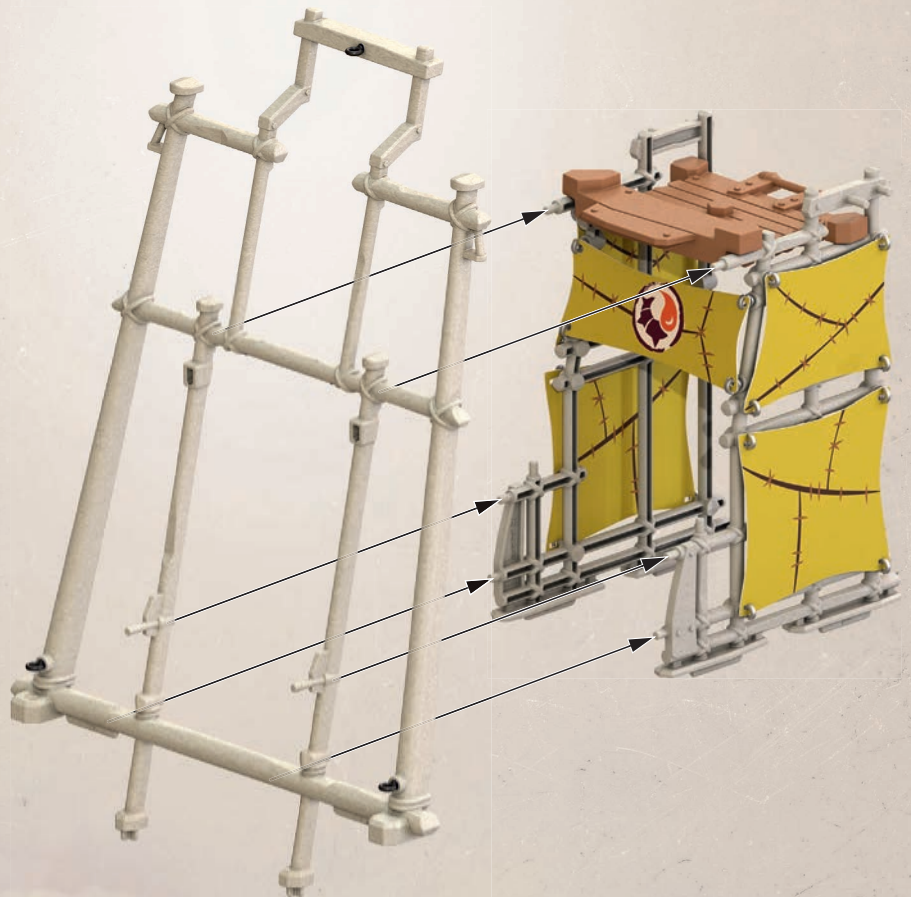



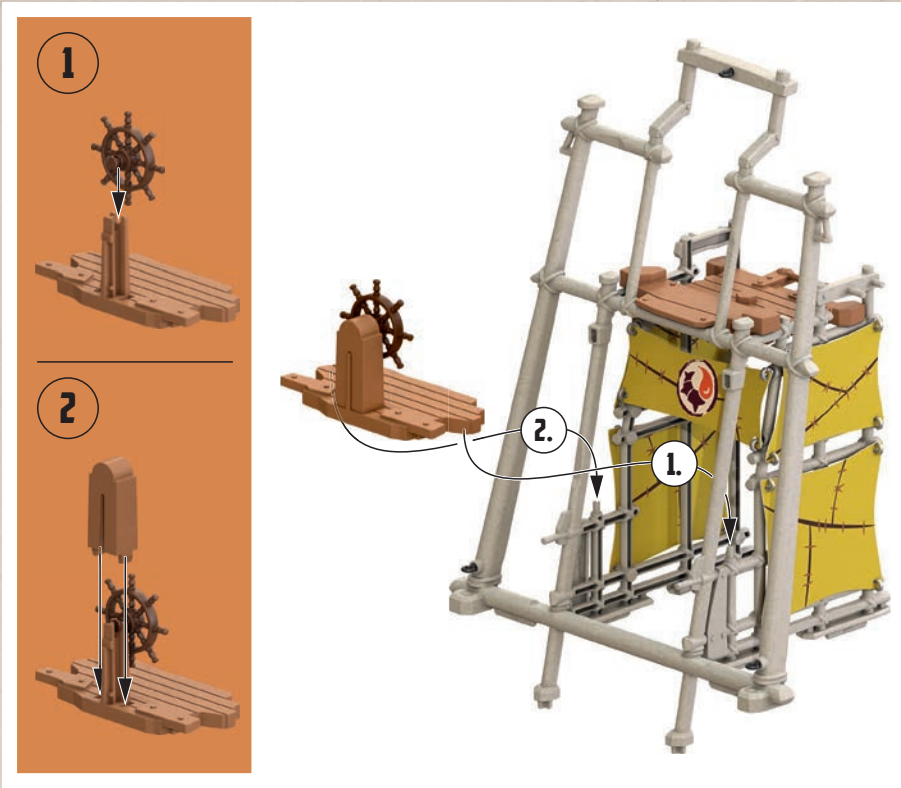

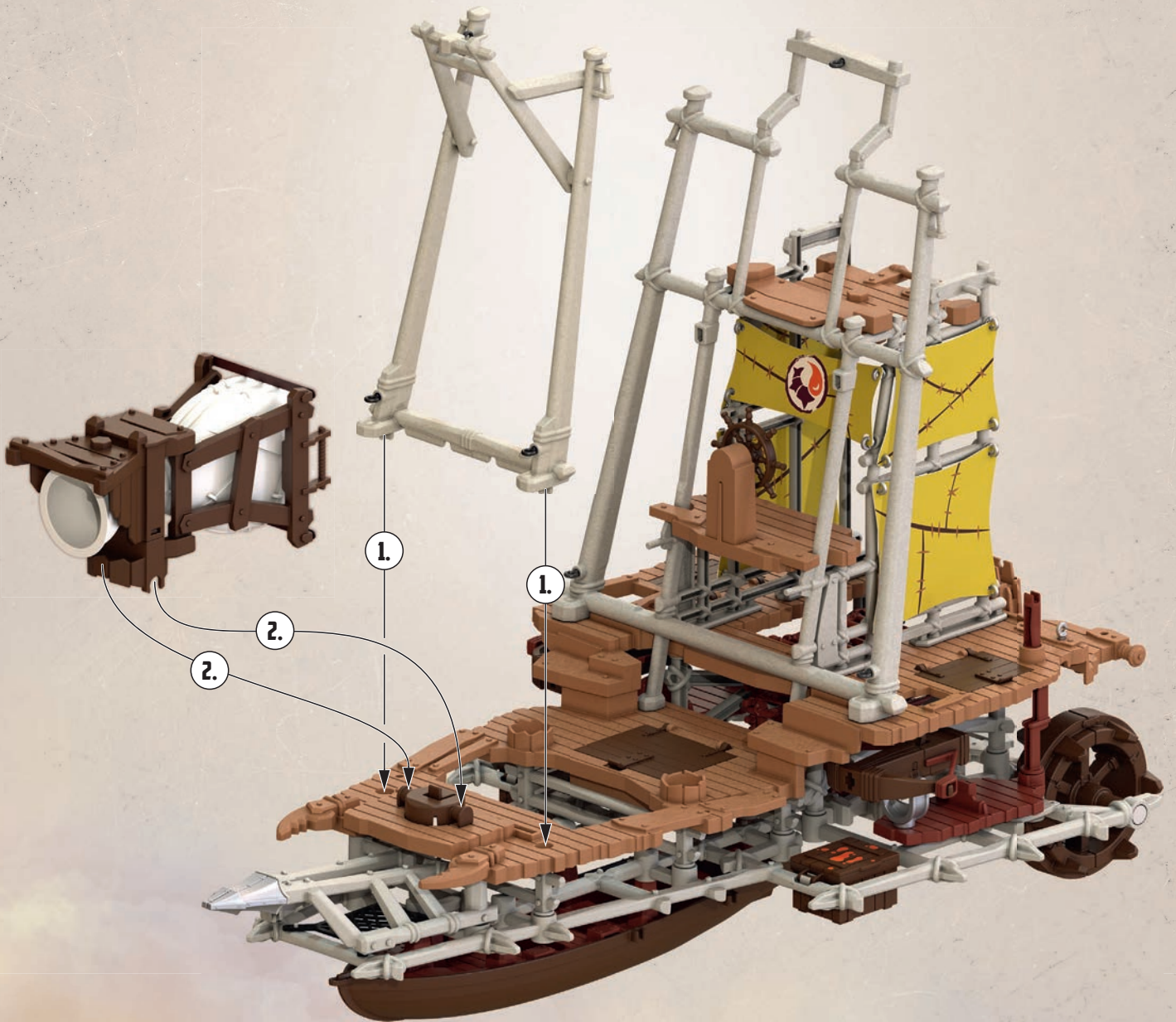
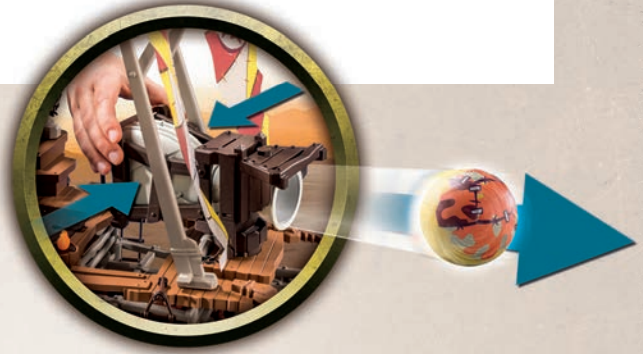
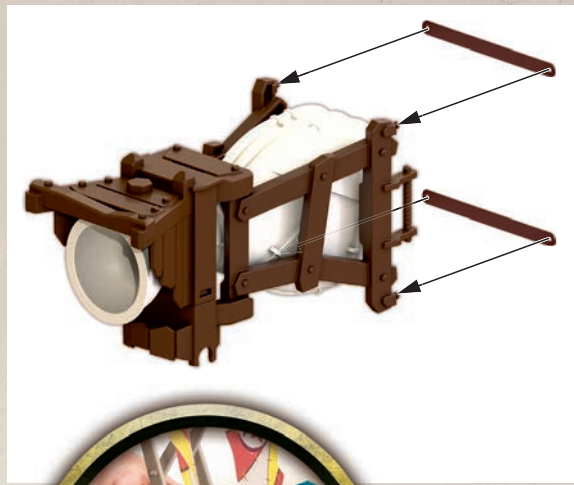



**1**

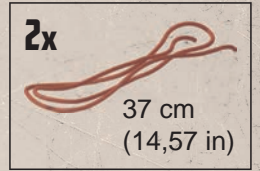
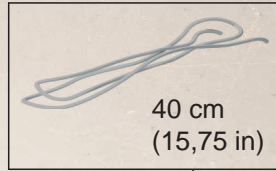
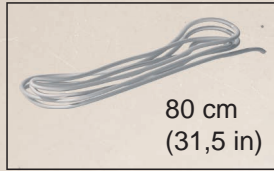
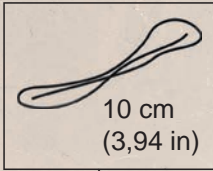
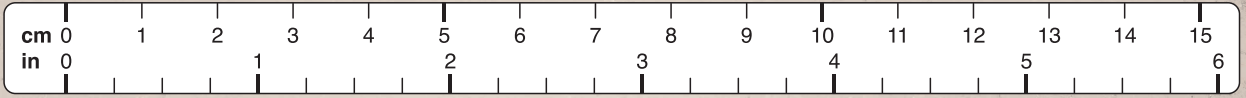

2

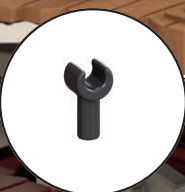
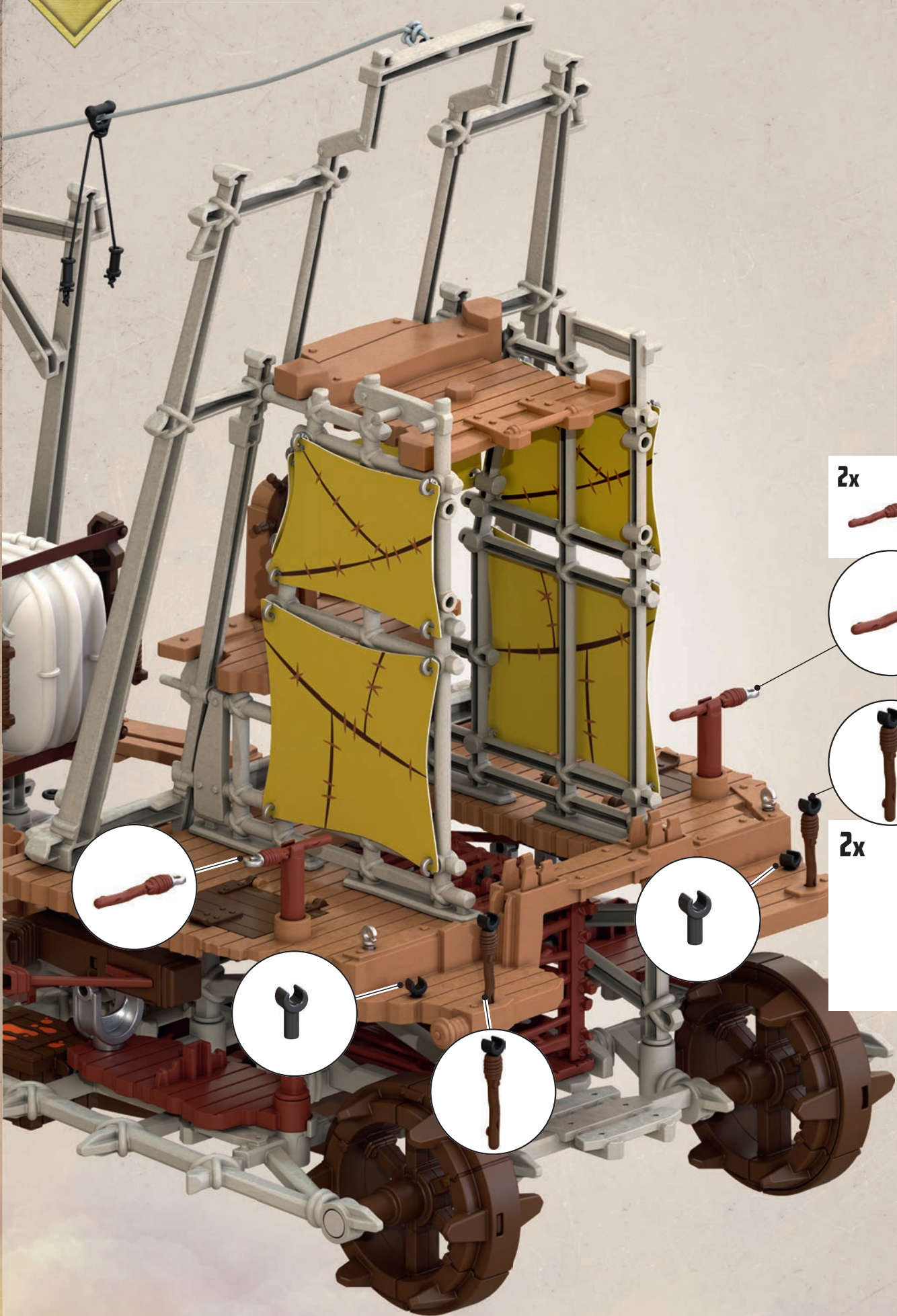

3

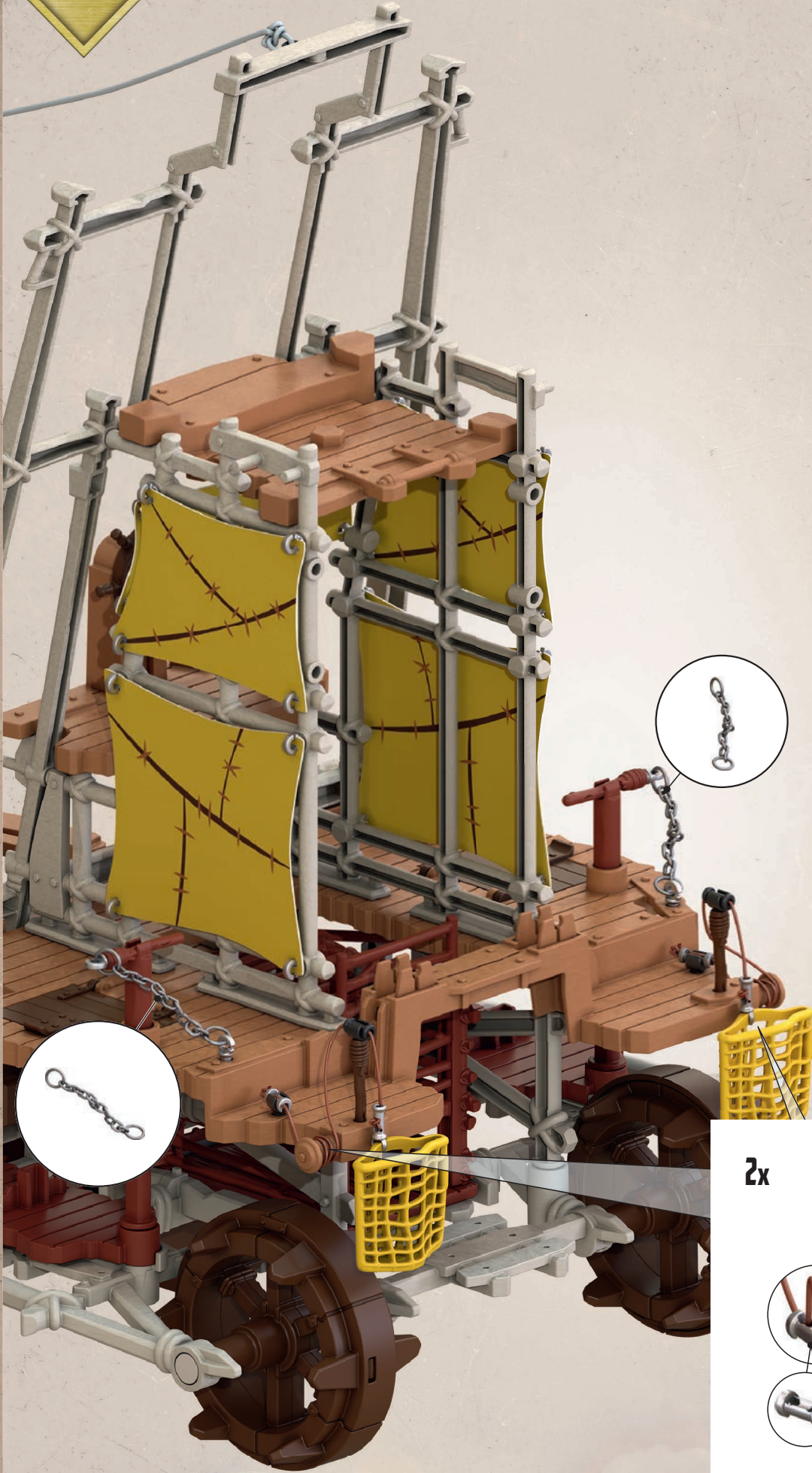

2x  
37 cm  
(14,57 in)

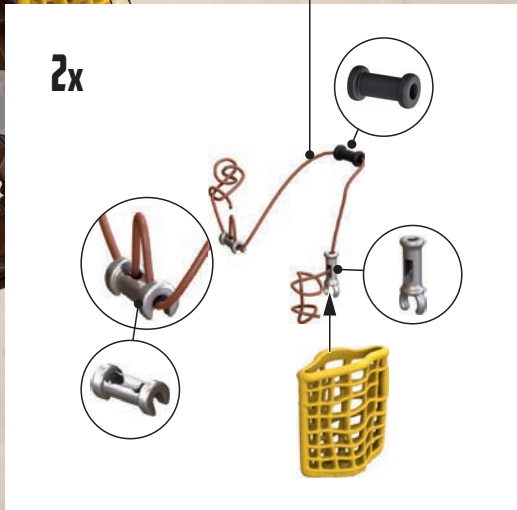
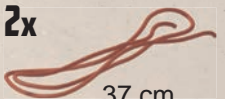

4

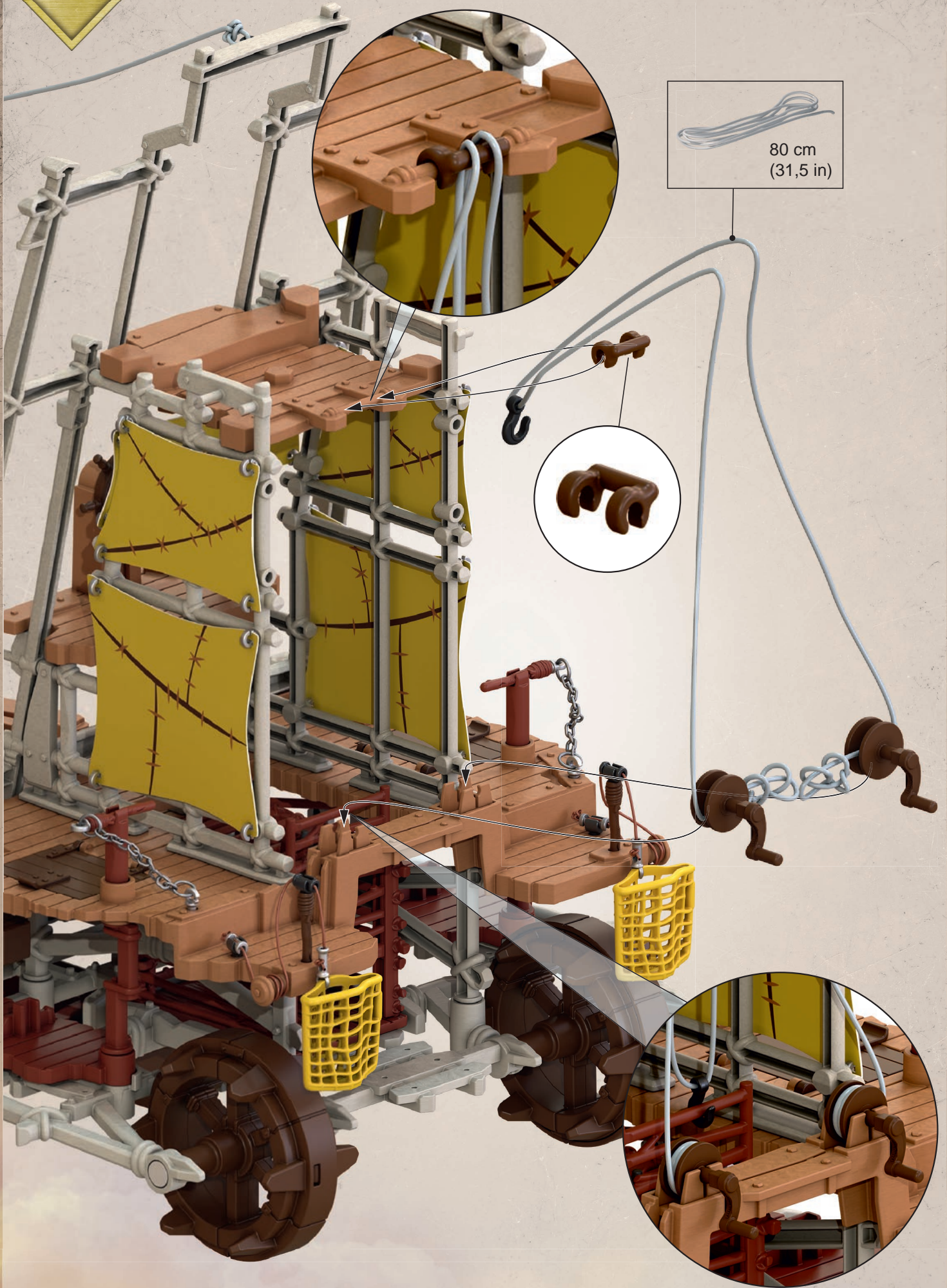

80 cm  
(31,5 in)

5

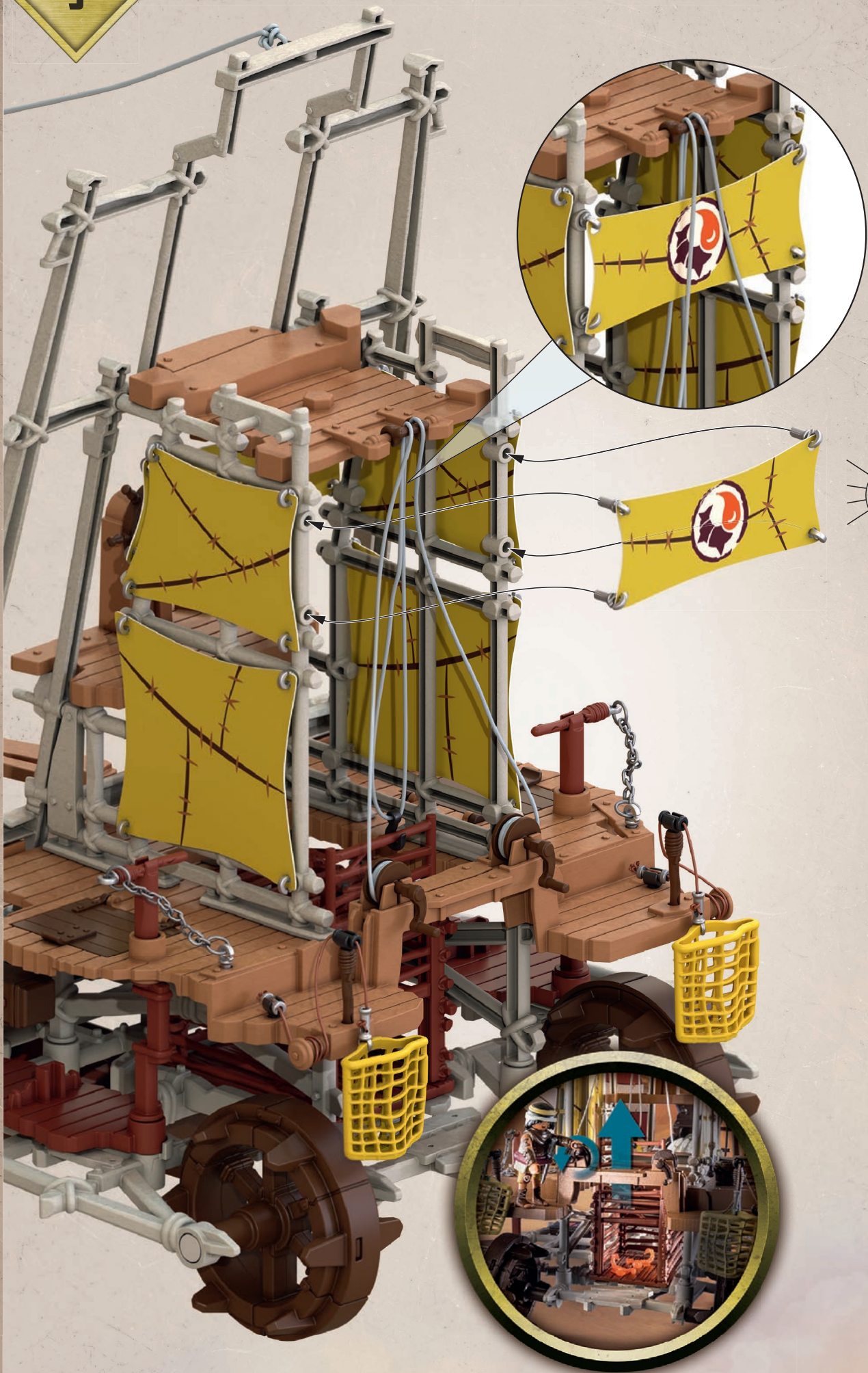

4x

A callout diagram showing a grey pin component with four lines radiating from its end, indicating its orientation or placement. The text "4x" is positioned above the pin.





1

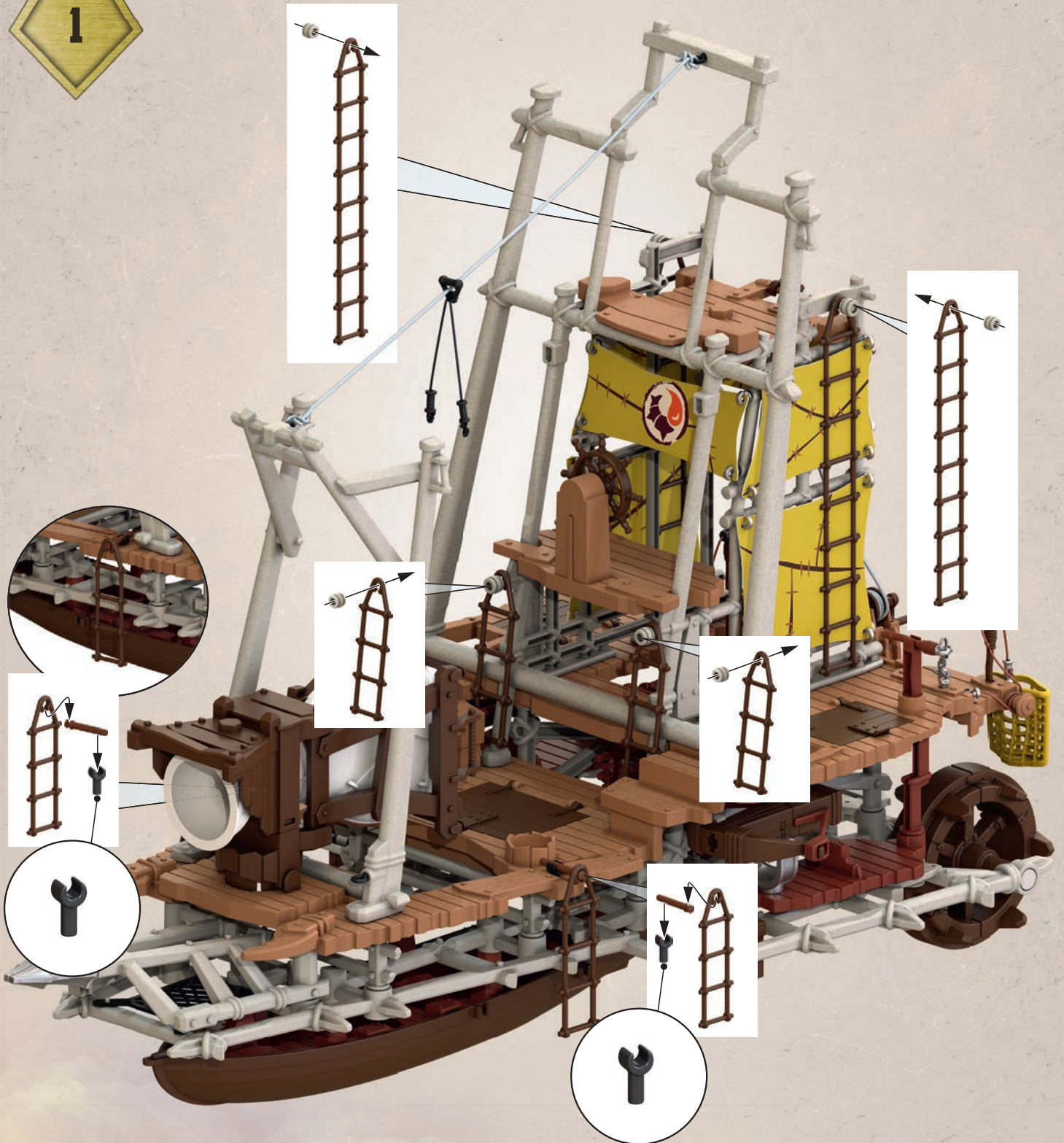



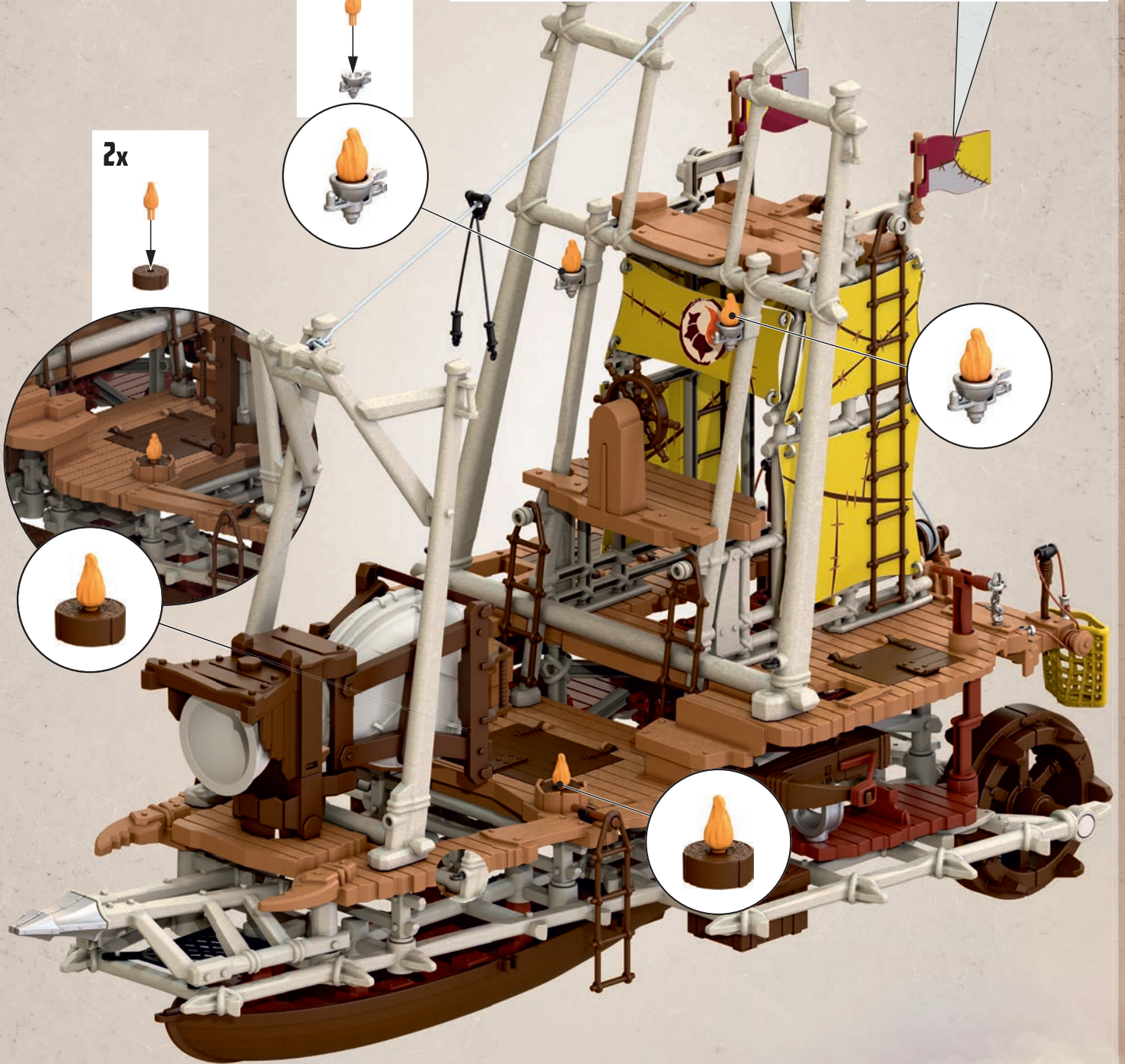
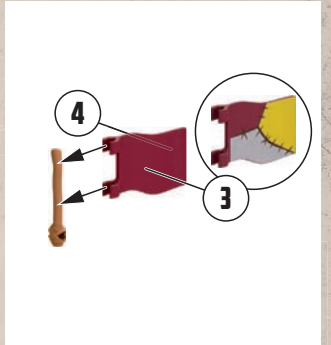
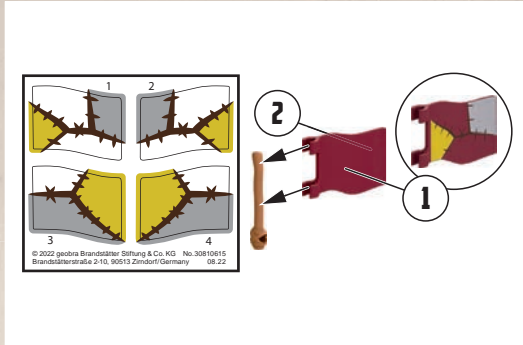

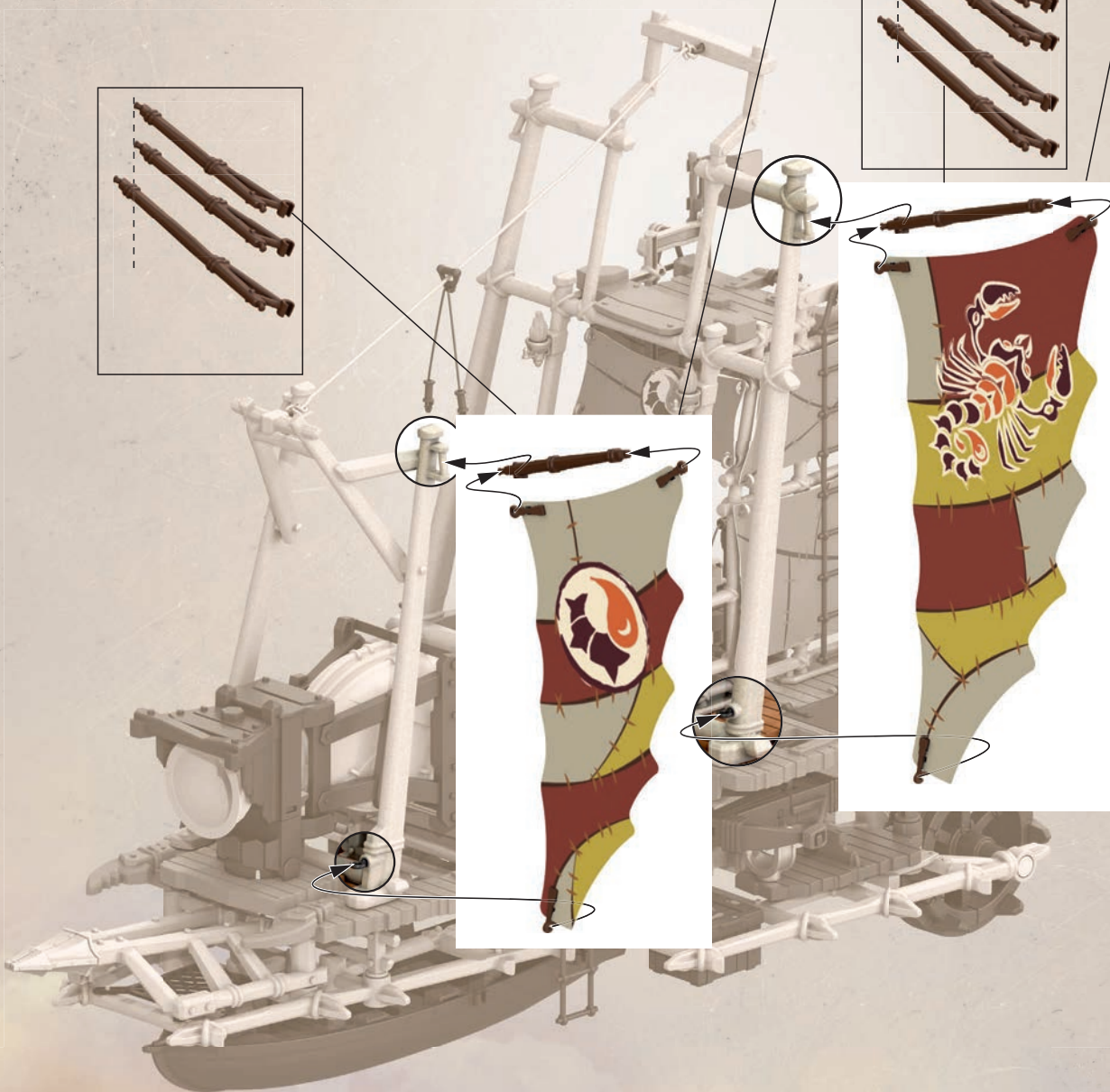
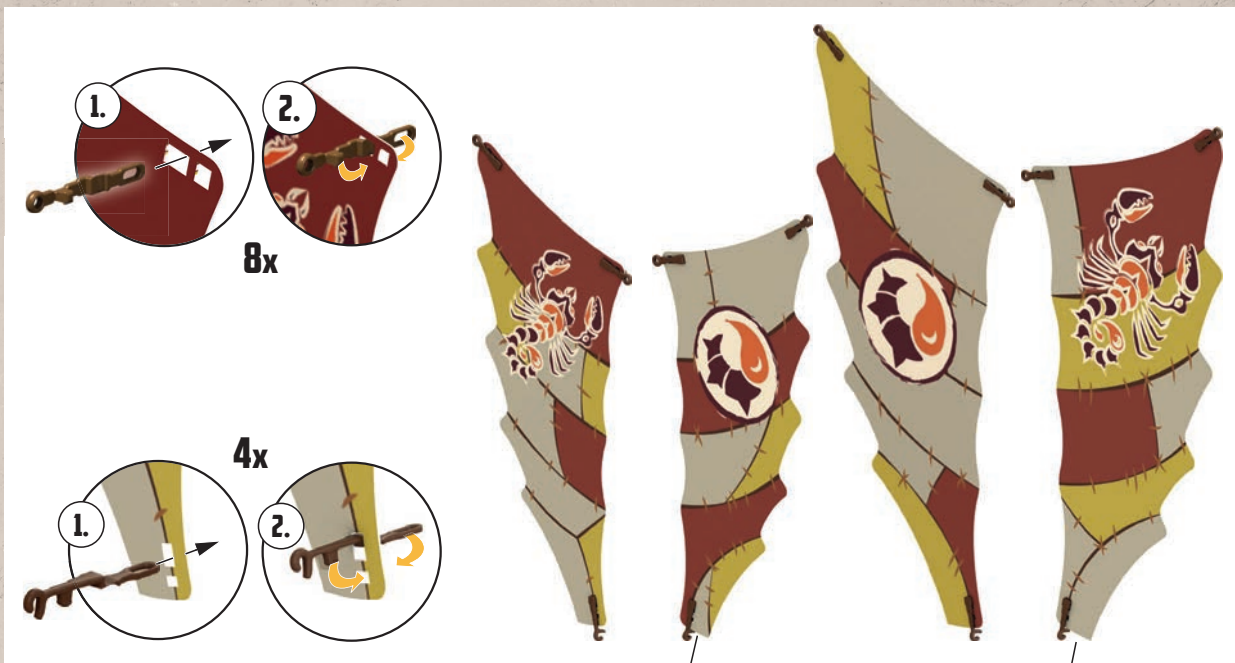

4

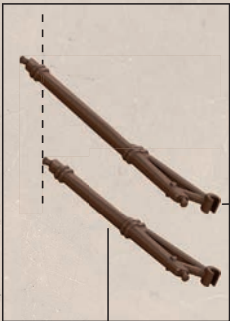
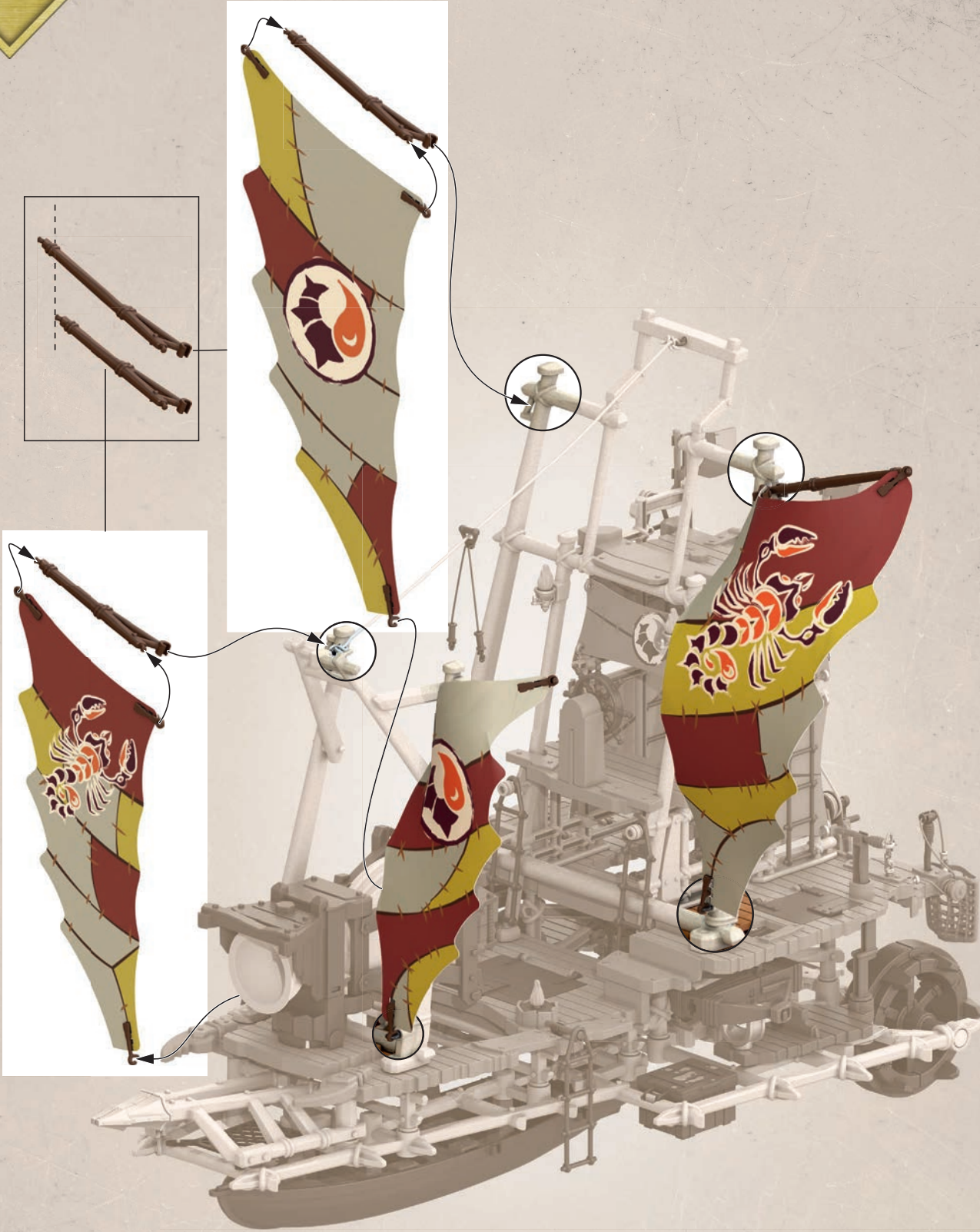

©2018 geobra Brandstätter  
 Stiftung & Co. KG  
 Industriepark Zirndorf 4711  
 90513 Zirndorf/Germany  
 No. 30881132 08.22





30 45 2613

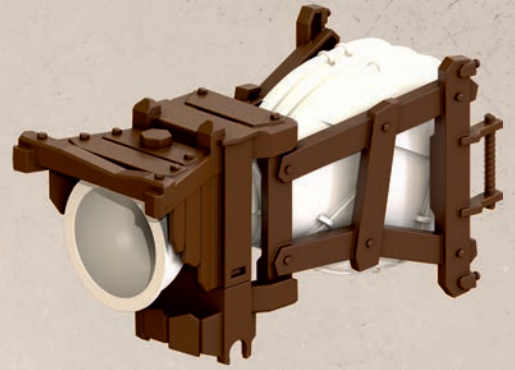

30 65 4675

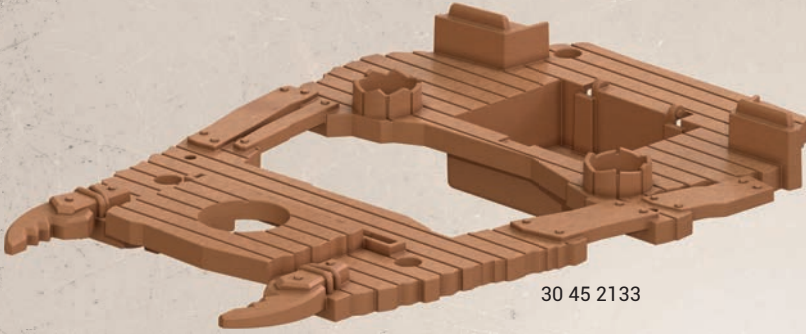

30 45 2133



30 51 3963

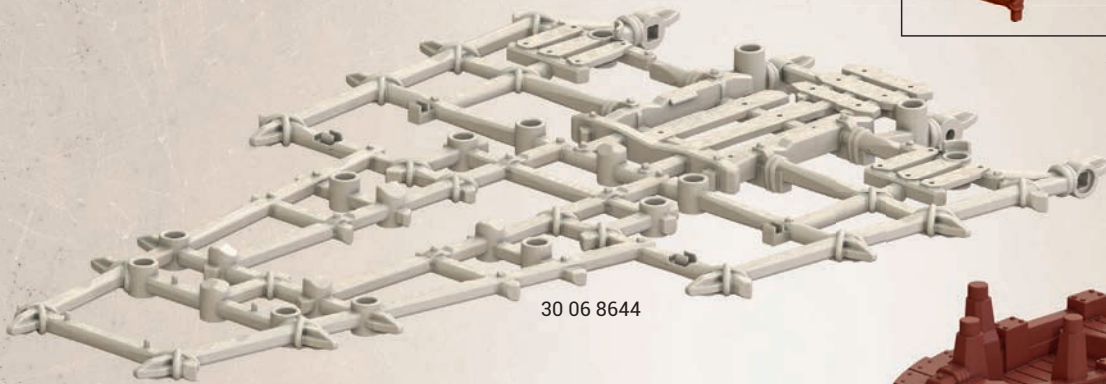

30 06 8644



30 06 8614



30 06 8624



30 06 8604

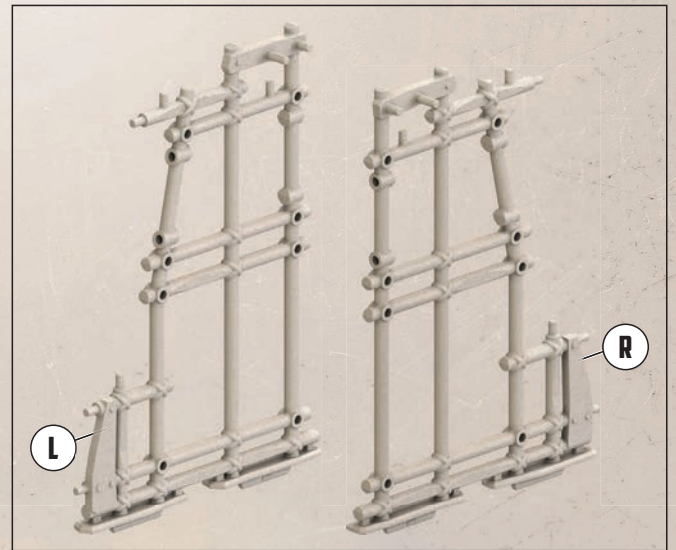

30 06 8634

30 51 4063

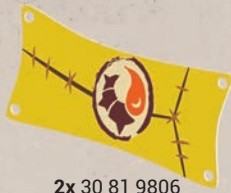

2x 30 81 9806



40 20 0290



2x 30 81 9846



2x 30 64 5717



2x 30 81 9876



30 81 9666



30 81 9776

30 81 9746



30 88 1132

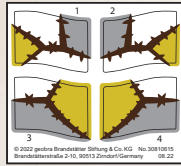

30 81 0615



6x 30 27 3920



28x 30 02 7442



2x 30 80 6395

30 81 9696



4x 30 03 8412



8x 30 06 8654



30 25 6493



30 00 2705



30 62 8308



30 06 8734



30 20 2904



30 62 6498

30 06 8694



30 06 8714



30 00 2695



2x 30 06 8704



30 20 6723



30 25 5983



30 20 3672



30 00 2455



30 06 5854

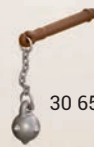

30 65 4685



30 14 6522



30 03 4154



2x 30 06 9912



30 24 5402



2x

3x

30 51 4073

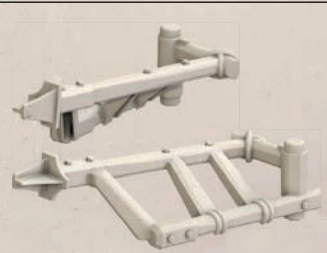

30 51 4083



2x 30 51 4093



30 06 8774

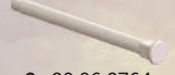

2x 30 06 8764



30 06 8754

2x 30 20 6953



2x 30 65 5125

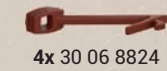

4x 30 06 8824



2x 30 20 6923



3x 30 06 6544



2x 30 67 3473



2x 30 06 8804



3x 30 06 6554



2x 30 06 8814

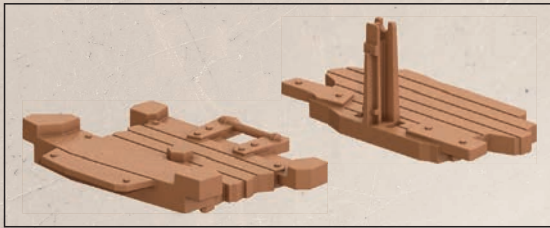

30 61 7312



30 08 4950



2x 30 06 8864



30 06 8834



30 06 8854



30 03 8262



30 06 8844

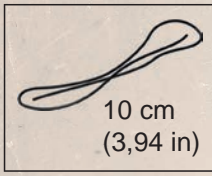

10 cm  
(3,94 in)

30 82 4382

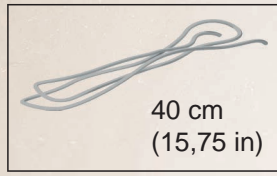

40 cm  
(15,75 in)

30 82 9374

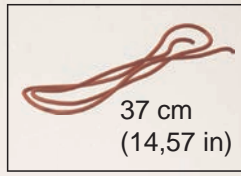

37 cm  
(14,57 in)

2x 30 82 5425

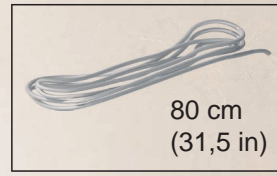

80 cm  
(31,5 in)

30 88 4632



2x 30 06 8904



2x 30 80 6534



2x 30 04 0132



2x 30 06 8874



30 04 0240



30 06 8884



30 09 5760



6x 30 02 8372



2x 30 23 7230



4x 30 07 5450



2x 30 24 0252



30 51 4123



2x 30 06 8944



4x 30 23 0392



4x 30 06 8934



2x 30 27 3120



2x 30 22 5852



2x 30 20 3872



2x 30 07 3992



4x 30 06 8924



2x 30 06 8914



30 25 9810



30 04 8133



30 62 8358



30 06 8974



30 06 8984



30 02 6760

30 06 8994



30 62 8348



5x 30 06 8954





71028



71028



71022



71027



71026



71028



71025



71023



71024

# NOVELMORE

playmobil®



Watch it on  
**YouTube** and  
**YouTube Kids**



**NOVELMORE**  
The Series

©2022 geobra Brandstätter Stiftung & Co. KG  
Brandstätterstr. 2-10  
90513 Zirndorf, Germany  
No. 30 81 0195 08.22



Actiongeladene Novelmore-Abenteuer  
**jetzt auch als Serie!** Folge uns auf  
unseren Social-Media-Kanälen.

Action-packed Novelmore adventures,  
**now a series!** Follow us on social media  
for exciting updates.

Continue les aventures des Novelmore  
avec notre **nouveau dessin animé!**  
Disponible sur nos réseaux sociaux !

Aventuras de Novelmore llenas de acción  
**¡ahora también como una serie!** Síguenos  
en nuestros canales de redes sociales.

[www.playmobil.com](http://www.playmobil.com)