

Astérix®

playmobil®

LAISSÉZ-LE
MOI!



71016

„ASTERIX DER GALLIER“

IM BEFESTIGTEN RÖMISCHEN LAGER KLEINBONUM STELLT MAN SICH FRAGEN: WIE SCHAFFEN ES DIE UNBEUGSAMEN GALLIER AUS DEM DORF VON ASTERIX, DIE RÖMISCHE MACHT IMMER UND IMMER WIEDER LÄCHERLICH ZU MACHEN? ENTSCLOSSEN, DAS GEHEIMNIS UM DIE ÜBERMENSCHLICHE KRAFT UNSERER HELDEN ZU LÜFTEN, SCHICKT DER ZENTURIO GAIUS BONUS EINEN ALS GALLIER VERKLEIDETEN SPION LOS. CALIGULA MINUS ÜBERNIMMT DIE AUFGABE

UND ENTDECKT SCHNELL DIE EXISTENZ DES VON MIRACULIX GEBRAUTEN ZAUBERTRANKS. KURZERHAND LÄSST DER ZENTURIO GAIUS BONUS DEN DRUIDEN ENTFÜHREN, UM AN DAS REZEPT DES BERÜHMTEN GETRÄNKES ZU GELANGEN. WER WEIß, VIELLEICHT WIRD ER JA SOGAR AN DIE STELLE VON JULIUS CÄSAR TRETEN? EINE ERSTE GELEGENHEIT FÜR ASTERIX, SEINEN MUT UND SEIN STRATEGISCHES TALENT UNTER BEWEIS ZU STELLEN.

“ASTERIX THE GAUL”

IN THE FORTIFIED ROMAN CAMP OF COMPENDIUM, QUESTIONS ARE BEING ASKED: HOW DO THE INDOMITABLE GAULS FROM ASTERIX'S VILLAGE MANAGE TO RIDICULE ROMAN POWER OVER AND OVER AGAIN? DETERMINED TO UNCOVER THE SECRET OF OUR HEROES' SUPERHUMAN STRENGTH, THE CENTURION CRISMUS BONUS SENDS OUT A SPY DISGUISED AS A GAUL.

CALIGULA MINUS TAKES ON THE TASK AND QUICKLY DISCOVERS THE EXISTENCE OF THE MAGIC POTION BREWED BY GETAFIX. WITHOUT FURTHER ADO, THE CENTURION CRISMUS BONUS HAS THE DRUID KIDNAPPED IN ORDER TO OBTAIN THE RECIPE FOR THE FAMOUS DRINK. WHO KNOWS, MAYBE HE WILL EVEN TAKE JULIUS CAESAR'S PLACE? A FIRST OPPORTUNITY FOR ASTERIX TO PROVE HIS COURAGE AND STRATEGIC TALENT.

"ASTÉRIX LE GAULOIS"

DANS LE CAMP FORTIFIÉ ROMAÏN PETIBONUM, ON SE POSE DES QUESTIONS : COMMENT LES IRRÉDUCTIBLES GAULOIS DU VILLAGE D'ASTÉRIX FONT-ILS POUR RIDICULISER ENCORE ET TOUJOURS LA PUISSANCE ROMAÏNE ? DÉCIDÉ À PERCER À JOUR LE MYSTÈRE DE LA FORCE SURHUMAÏNE DE NOS HÉROS, LE CENTURION CAIUS BONUS ENVOIE UN ESPION DÉGUISÉ EN GAULOIS.

C'EST CALIGULA MINUS QUI S'Y COLLE, ET DÉCOUVRE BIEN VITE L'EXISTENCE DE LA POTION MAGIQUE PRÉPARÉE PAR PANORAMIX. SANS

ATTENDRE, LE CENTURION CAIUS BONUS FAIT ENLEVER LE DRUÏDE POUR S'EMPARER DE LA RECETTE DU FAMEUX BREUVAGE HISTOÏRE, QUI SAÏT, DE DEVENIR CÉSAR À LA PLACE DE JULES ! UNE PREMIÈRE OCCASION POUR ASTÉRIX DE DÉMONTRER SON COURAGE ET SES TALENTS DE STRATÈGE.

"ASTÉRIX EL GALO"

EN EL CAMPAMENTO ROMANO DE PETIBONUM SE PLANTEAN PREGUNTAS: ¿CÓMO CONSIGUEN LOS INDOMABLES GALOS DE LA ALDEA DE ASTÉRIX RIDICULIZAR EL PODER ROMANO UNA Y OTRA VEZ? DECIDIDO A DESCUBRIR EL SECRETO DE LA FUERZA SOBREHUMANA DE NUESTROS HÉROES, EL CENTURIÓN CAIUS BONUS ENVÍA A UN ESPÍA DISFRAZADO DE GALO.

CALIGULA MINUS ASUME LA TAREA Y RÁPIDAMENTE

DESCUBRE LA EXISTENCIA DE LA POCIÓN MÁGICA ELABORADA POR PANORÁMIX. SIN MÁS DILACIÓN, EL CENTURIÓN CAIUS BONUS SECUESTRA AL DRUÏDA PARA OBTENER LA RECETA DE LA FAMOSA BEBIDA Y, QUIÉN SABE, ¿QUIZÁS OCUPE EL LUGAR DE JULIO CÉSAR? UNA PRIMERA OPORTUNIDAD PARA QUE ASTÉRIX DEMUESTRE SU VALOR Y SU TALENTO ESTRATÉGICO.

CACOFONIX

WORLD-RENOWNED POET AND BARD (IF NOT EXACTLY APPRECIATED) AND RESPECTED SCHOOL TEACHER, CACOFONIX IS AN IMPORTANT FIGURE IN THE VILLAGE. HOWEVER, AS THE ETERNAL BUTT OF THE VILLAGERS JOKES, CACOFONIX LIVES ON THE FRINGE, IN A HUT BUILT AT THE TOP OF A TREE. WHEN IT IS TIME TO PARTY, WHEN WILD BOAR ARE ROASTING ON THE SPIT, YOU CAN BE SURE TO FIND CACOFONIX TIED HAND AND FEET WITH A GAG IN HIS MOUTH.

ASURANCETÚRIX

POETA Y BARDO DE FAMA MUNDIAL (SIN SER DEL TODO APRECIADO...) Y PROFESOR RESPETADO, ASURANCETÚRIX ES UNA FIGURA IMPORTANTE EN LA ALDEA. SIN EMBARGO, SI ES CONOCIDO POR TODOS, ES SOBRE TODO POR SER EL ETERNO DESPRECIADO POR PARTE DE LOS HABITANTES DE LA ALDEA, DE LA CUAL ES EL REPRESENTANTE MÁS MARGINAL, QUE VIVE APARTADO EN UNA CHOZA CONSTRUIDA EN LA COPA DE UN ÁRBOL. EN DÍAS DE CELEBRACIÓN, CUANDO LOS JABALÍES SE ESTÁN ASANDO, PODÉIS ESTAR SEGUROS DE QUE LO ENCONTRARÉIS AMORDAZADO Y ATADO DE PIES Y MANOS.

ASSURANCETOURIX

BARDE À LA VOIX MONDIALEMENT CÉLÈBRE (À DÉFAUT D'ÊTRE APPRÉCIÉE...) ET INSTITUTEUR RESPECTÉ, ASSURANCETOURIX EST UNE FIGURE IMPORTANTE DU VILLAGE. POURTANT, S'IL EST CONNU DE TOUS, C'EST SURTOUT EN TANT QU'ÉTERNEL SOUFFRE-DOULEUR DES HABITANTS DU VILLAGE. IL VIT À L'ÉCART DANS UNE HUTTE BÂTIE AU SOMMET D'UN ARBRE. ET ON PEUT CERTAINEMENT S'ATTENDRE À LE TROUVER PIEDS ET POINGS LIÉS LORSQUE LES AUTRES GAULOIS CÉLÈBRENT L'UNE DE LEURS FAMEUSES FÊTES.

TROUBADIX

TROUBADIX IST EIN WELTBERÜHMTER (WENN AUCH NICHT BELIEBTER) BARDE UND EIN ANGESEHENER LEHRER, DER EINE WICHTIGE FIGUR IM DORF IST. DENNOCH IST ER ALLEN BEKANNT, VOR ALLEM ALS DER EWIGE PRÜGELKNABE DER DORFBEWÖHNER. ER LEBT ABGESCHIEDEN IN EINER HÜTTE, DIE IN DEN WIPFELN EINES BAUMES ERRICHTET WURDE. UND MAN KANN SICHER DAVON AUSGEHEN, DASS MAN IHN AN HÄNDEN UND FÜßEN GEFESSELT VORFINDET, WENN DIE ANDEREN GALLIER EINES IHRER BERÜHMTE FESTE FEIERN.



GERIATRIX'S WIFE

AN ELEGANT VILLAGER, SHE IS THE ONLY WOMAN IN THE VILLAGE WHO DOES NOT TAKE CARE OF THE HOUSEWORK. CHARACTERIZED BY GREAT JEALOUSY, SHE CAN USE HER FISTS WHEN NECESSARY.

MME EDADEPIEDRIX

ELEGANTE ALDEANA, ES LA ÚNICA MUJER DEL PUEBLO QUE NO SE OCUPA DE LAS TAREAS DOMÉSTICAS. MUY CELOSA, SABE USAR LOS PUÑOS CUANDO ES NECESARIO.

MME AGECANONIX

ÉLÉGANTE DU VILLAGE, ELLE EST LA SEULE FEMME DU VILLAGE À NE PAS S'OCUPER DES TÂCHES MÉNAGÈRES. D'UNE GRANDE JALOUSIE, ELLE SAIT JOUER DES POINGS QUAND IL LE FAUT.

FRAU METHUSALIX

ALS ELEGANTE DORFBEWÖHNERIN IST SIE DIE EINZIGE FRAU IM DORF, DIE SICH NICHT UM DEN HAUSHALT KÜMMERT. VON GROßER EIFERSUCHT GEPRÄGT, KANN SIE, WENN NÖTIG, IHRE FÄUSTE EINSETZEN.



**NEU NEW
NOUVEAU
NUEVO**



**AUFBAUEN LEICHT GEMACHT MIT NUMMERIERTEN TÜTEN.
VIEL SPAß MIT DEINEM NEUEN PLAYMOBIL-SPIELZEUG!**

**SET-UP MADE EASY WITH NUMBERED BAGS.
HAVE FUN WITH YOUR NEW PLAYMOBIL TOY!**

**SIMPLICITÉ DE MONTAGE AVEC LES SACHETS NUMÉROTÉS.
AMUSE-TOI AVEC TES NOUVEAUX PLAYMOBIL!**

**EL MONTAJE ES MÁS FÁCIL
CON LAS BOLSAS NUMERADAS.
¡DIVIÉRTETE CON TU NUEVO
JUGUETE DE PLAYMOBIL!**





WARNING: CHOKING HAZARD

Small parts. Not for children under 3 years.

"Ne concerne que les USA"

UK-Importer:
Playmobil UK Ltd.
Regency House
1 Miles Gray Road
Basildon
Essex
SS14 3RW
UK

**UK
CA**



Wichtige Unterlagen, bitte sorgfältig aufbewahren!
Important: Please keep these instructions for future reference!
Documents importants, à conserver soigneusement!
¡Por favor, guarde estas instrucciones para el futuro!
Belangrijke documenten, bewaar deze zorgvuldig!

Abbildungen können vom Original abweichen.
Product may differ from image shown.
Les illustrations peuvent différer de l'original.
Las ilustraciones pueden diferir del original.
Afbeeldingen kunnen verschillen van het werkelijke artikel.

Serviceadressen finden Sie in allen
PLAYMOBIL-Prospekten

Addresses of Customer Service Depart-
ments are shown in all PLAYMOBIL
catalogues

L'adresse du service consommateurs
est indiquée dans tous les catalogues
PLAYMOBIL

Troverete gli indirizzi dei centri di
assistenza in tutti i cataloghi PLAYMOBIL

In alle PLAYMOBIL catalogi vindt u
het adres van onze klantendienst.

Las Direcciones de los Departamentos
de Servicio al Consumidor se encuentran
en todos los catálogos PLAYMOBIL

Η διεύθυνση του Γραφείου Εξυπηρέτησης
Καταναλωτών PLAYMOBIL βρίσκεται σε
όλους τους καταλόγους PLAYMOBIL.

pronounced: plāy-mō-bēil

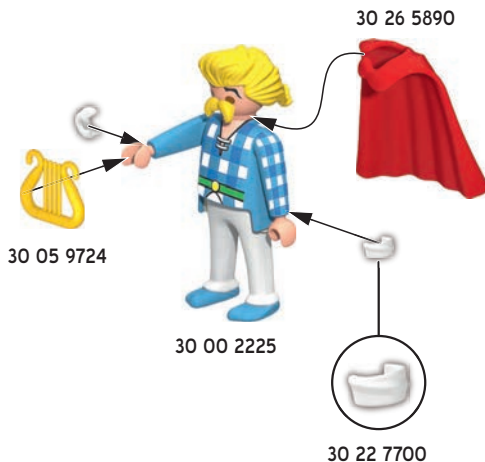

1

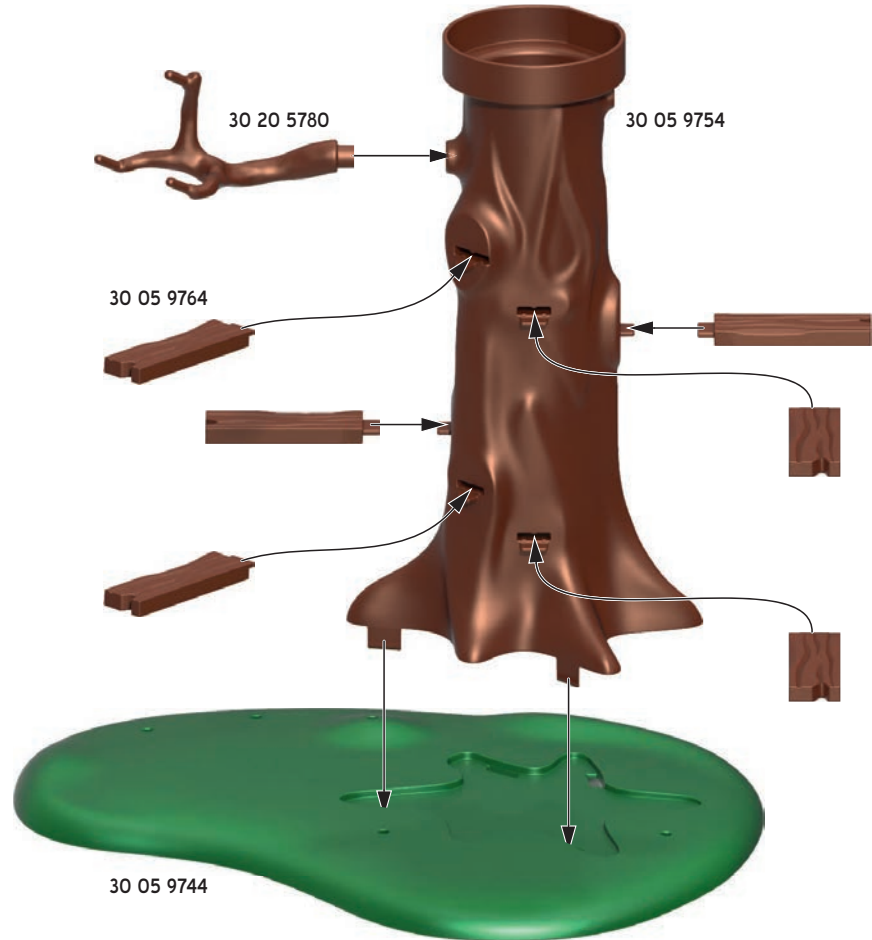

2

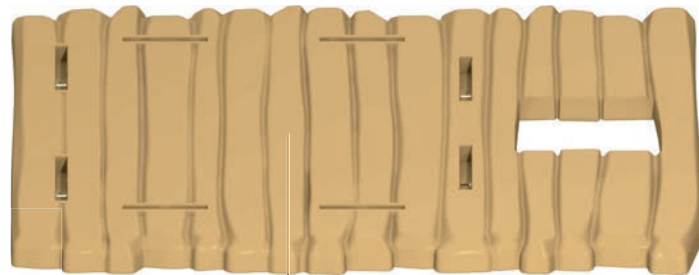

30 05 9774



3

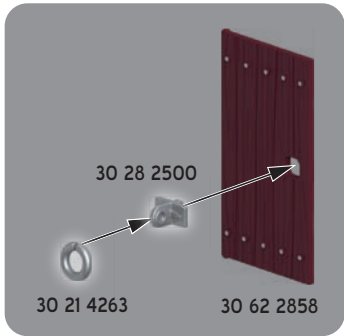

4



5

30 05 9784





30 05 9814





30 21 3803

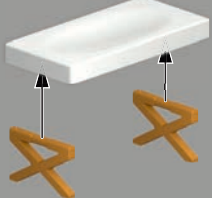

30 05 9824

30 05 9894



30 05 9884



30 05 9874



30 25 5902



30 03 3343



30 05 8714

30 83 0130



30 22 2522

30 62 2868



30 25 0570

30 08 5672



30 05 8634



30 51 3693



30 51 3683





30 09 5209



30 22 0743



30 09 2110

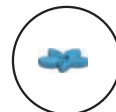

30 02 5792



30 05 8854

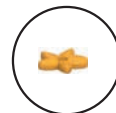

30 09 0432



30 22 5790

30 22 5780

2x



30 24 9800





70931



71160



70933



71015



70934



71016



70932

Astérix®



ASTERIX® OBELIX® IDEFIX® © 2022 LES EDITIONS ALBERT RENE / GOSCINNY-UDERZO



© 2022 geobra Brandstätter Stiftung & Co. KG
Brandstätterstr. 2-10
90513 Zirndorf, Germany
No. 30 81 9156 04.22