

playmobil®  
70197



**WARNING:**  
**CHOKING HAZARD**

Small parts. Not for children under 3 years.

"Ne concerne que les USA"

Wichtige Unterlagen, bitte sorgfältig aufbewahren !  
Important: Please keep these instructions for future reference !  
Documents importants, à conserver soigneusement !  
Belangrijke documenten, bewaar deze zorgvuldig !



Serviceadressen finden Sie in allen Playmobil-Prospekten

Addresses of Customer Service Departments are shown in all Playmobil catalogues

L'adresse du service consommateurs est indiquée dans tous les catalogues Playmobil

Troverete gli indirizzi dei centri di assistenza in tutti i cataloghi Playmobil

In alle PLAYMOBIL catalogi vindt u het adres van onze klantendienst.

Las Direcciones de los Departamentos de Servicio al Consumidor se encuentran en todos los catálogos Playmobil

Η διεύθυνση του Γραφείου Εξυπηρέτησης Καταναλωτών PLAYMOBIL βρίσκεται σε όλους τους καταλόγους PLAYMOBIL.

pronounce: plāy-mō-bēēl



www.playmobil.com

1

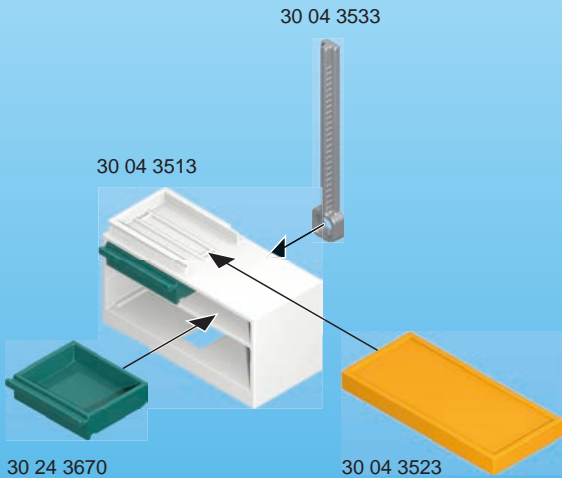

2

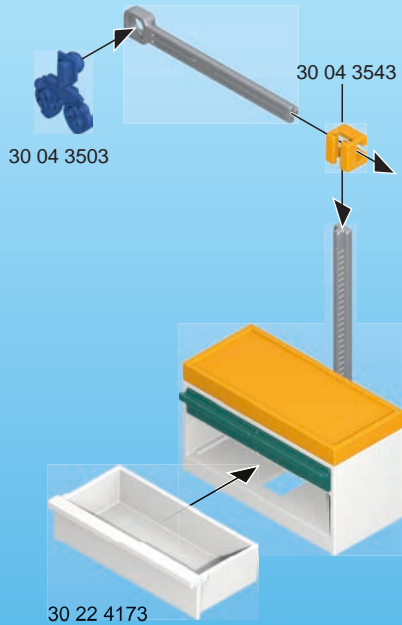

2



30 82 2725

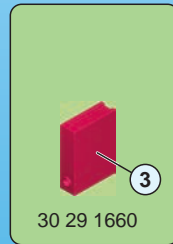
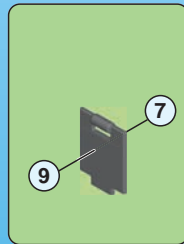
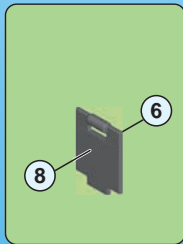
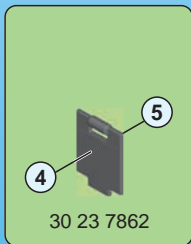
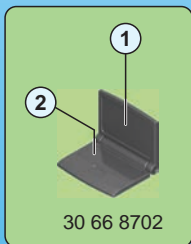
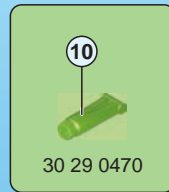
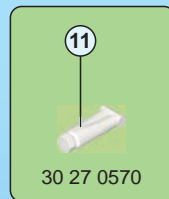
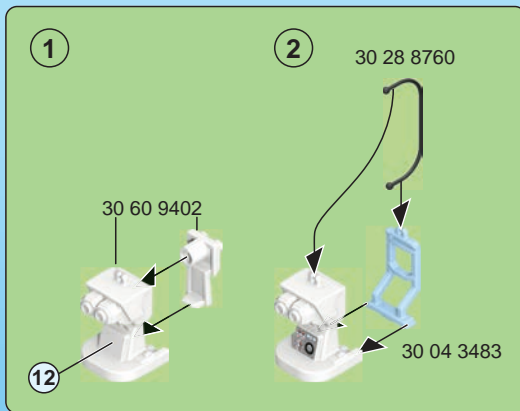

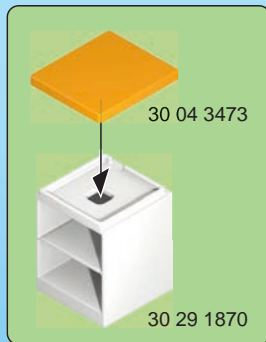

Abbildungen können vom Original abweichen. / Product may differ from image shown.  
Les illustrations peuvent différer de l'original. / Afbeeldingen kunnen verschillen van het werkelijke artikel.



30 62 8846

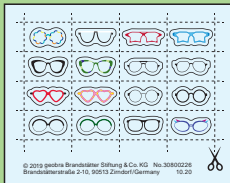

© 2019 geobra Brandstätter Stiftung & Co. KG No. 30800226  
Brandstätterstraße 2-10, 90513 Zinsdorf/Germany 10.20

30 80 0226



- DE AT CH LU BE repositionierbar  
US GB CA MT IE repositionable  
FR CA BE LU CH repositionnable  
ES MX reposicionable  
NL BE herpositioneerbaar  
IT CH riposizionabile

- DE AT CH LU BE** Zu-/Ausschneiden mit einer Kinderschere unter Aufsicht von Erwachsenen.
- US GB CA MT IE** Cut or cut out using children's scissors under adult supervision.
- FR CA BE LU CH** Procéder au découpage/à la mise à longueur avec des ciseaux pour enfants sous la surveillance d'adultes.
- ES MX** Cortar / recortar con tijeras para niños, bajo la supervisión de adultos.
- NL BE** Knippen/uitknippen met een kinderschaar onder toezicht van volwassenen.
- IT CH** Tagliare/ritagliare con una forbice per bambini sotto la sorveglianza di un adulto.
- PT** Realizar cortes com uma tesoura para crianças sob vigilância de um adulto.
- DK** Klippes til og klippes ud med en børnesaks under opsyn af en voksen.
- NO** Klippes ut med barnesaks under tilsyn av en voksen.
- SE FI** Barn får endast klippa till/klippa ut något med barnsaxen under uppsikt av en vuxen.
- FI** Leikataan lasten saksilla aikuisten valvonnassa.
- HU** Ki-/levágása gyermekollóval, felnőtt felügyelete mellett történik.
- CZ** Používání dětských nůžek na stříhání / vystřihování musí být pod dohledem dospělé osoby.
- EE** Väljalõikamine lastekääridega on lubatud üksnes täiskasvanute järelevalve all.
- LV** Izgrieziet atr bērnu šķērēm pieaugušo uzraudzībā.
- LT** Kerpant vaikiškoms žirkėmis vaiką turi prižiūrėti suaugęs asmuo.
- SI** Prerezovanje/izrezovanje s škarjami za otroke pod nadzorom odraslih.
- SK** Použitvanie detských nožníc na strihanie / vystrihávanie musí byť pod dohľadom dospelých.
- PL** Do wycinania nożyczkami dla dzieci pod kontrolą osób dorosłych.
- TR CY** Çocuk makasıyla bir yetişkinin denetimi altında kesilmelidir.
- GR CY** Κόβετε με παιδικό ψαλίδι υπό την επίβλεψη ενηλίκων.
- RO** Decuparea/ajustarea lungimii se face cu un foarfece pentru copii sub supravegherea unor adulți.
- BG** Рязането/изрязването с детска ножица да става под надзора на възрастен.
- HR** Rezanje/izrezivanje škarama pod nadzorom odraslih.
- CN** 在成年人的照看下用儿童剪刀裁切 / 剪下。